

RADIODETECTION®

SuperCAT®4 and T1 transmitter range













User guide

90/UG110EN/03



SPX®

ALWAYS DIG WITH CAUTION

-  Risk of property damage, death, or serious injury may result if buried pipes and cables are not properly located before digging.
-  Read and follow all instructions and warnings in this user guide before using the SuperCAT4+ and T1 transmitter.
-  Regularly check your SuperCAT4+ and T1 transmitter, in all modes, over a cable which gives a response you are familiar with.
-  Some power cables DO NOT radiate detectable power signals.
-  Power and Radio signals may not be present. It is advisable to use the T1 transmitter whenever searching for pipes and cables.
-  Do not use the SuperCAT4+ depth estimation function to decide if mechanical digging over a buried conductor is appropriate.
-  StrikeAlert™ may not activate even if a live power cable is present.
-  The presence of 'StrikeAlert Activated' label does not guarantee that this feature is activated.
-  Keep mobile phones away from cable and pipe locators when in operation. Minimum distance 60cm/24" recommended.
-  The SuperCAT4+ cannot indicate whether a signal comes from a single conductor or from several cables or pipes bundled or buried in close proximity to each other.
-  It is recommended that the SuperCAT4+ and T1 transmitter are serviced at least once a year and have their calibration validated using Radiodetection approved test equipment. Radiodetection will accept no responsibility for repairs carried out by unauthorized repairers.
-  Even if using a SuperCAT4+ and T1 transmitter, ALWAYS DIG WITH CAUTION.

Call your local support number (available from: www.radiodetection.com) for questions regarding the proper use, maintenance, and repair of the SuperCAT4+ and T1 transmitter.

SuperCAT4 range

Modes / features	+	S	CPS
StrikeAlert	✓	✓	✓
Depth	✓	✓	✓
Sonde 512/640 Hz*	✓	✓	
Sonde MF 8 kHz		✓	
Sonde HF 33 kHz	✓	✓	
Active Line 512/640 Hz*	✓		✓
Active Line 8 kHz	✓		✓
Active Line 33 kHz	✓	✓	✓
Active Line 65 kHz	✓		
Super HF 131 kHz	✓		
CPS**			✓
Radio	✓	✓	✓
Power 50 Hz/60 Hz*	✓	✓	✓

*Set by power frequency: 50/640Hz or 60/512 Hz

**Set by power frequency: 50/100Hz or 60/120Hz

T1 transmitter range

	512	640	512/65	640/65	131
Induction 8 kHz	✓	✓	✓	✓	✓
Induction 33 kHz	✓	✓			✓
Induction 65 kHz			✓	✓	
Direct Connect 512 Hz	✓		✓		
Direct Connect 640 Hz		✓		✓	
Direct Connect 8 kHz	✓	✓	✓	✓	✓
Direct Connect 33 kHz	✓	✓			✓
Direct Connect 65 kHz			✓	✓	
Direct Connect 131 kHz					✓

SuperCAT4+ user guide

This user guide covers all models of the SuperCAT4+ locator range.

Locator functions

- 1. On/Off Trigger.**
Press and hold to use the locator.
- 2. LCD Screen** with automatic depth readout and frequency selection button.
- 3. Loudspeaker.**
Detachable speaker for use in noisy environments.
- 4. Sensitivity Control.**
- 5. Mode Selector Switch.**
- 6. Battery compartment.**

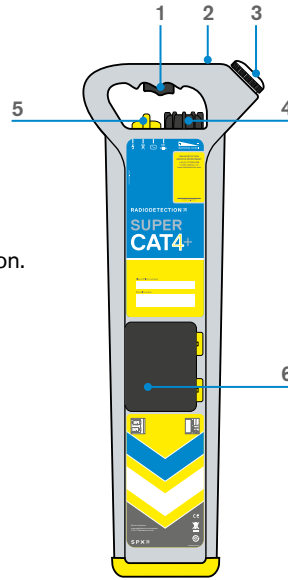

Screen features

The locator's screen displays the following features:

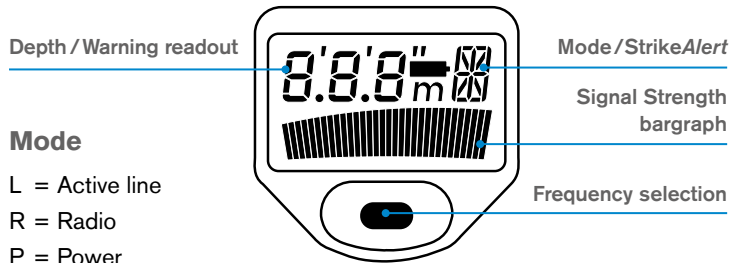

Mode

- L = Active line
- R = Radio
- P = Power
- S = Sonde
- or
- C = CPS (CPS model)

Speaker

When using the locator in noisy environments, the speaker can be detached and held closer to the ear.

⚠ To avoid excessive noise exposure, hold the speaker no closer than 15cm (6") from the ear. Prolonged use in this position should be avoided.

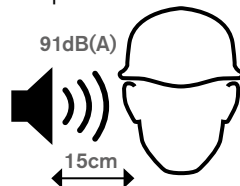

Using the locator

Grip the locator's handle. Press and hold the trigger and listen for the bleep indicating the batteries are OK. Replace both batteries if there is no bleep or if the battery icon is flashing.

When required, use the frequency selection button to cycle between operating frequencies.

Hold the locator with the blade vertical and with the lower edge just above the ground. Do not swing it or tilt it more than a few degrees from the vertical.

Swinging the locator will affect locate accuracy.

Depth Measurement

The locator will automatically measure and display the depth in Active Line, sonde and CPS modes.

Note: The locator does not measure depth in Power or Radio modes.

Method: Locate the utility as follows. Hold the locator still and vertically centered above the detected line and across the line of the pipe/cable.

Note: A depth measurement will not be displayed where environmental conditions are poor (e.g. weak signal or interference).

The measurement is to the center of the pipe/conductor or to the center of the sonde, which may rest at the bottom of the pipe.

Do not use the depth measurement function to decide if mechanical digging is appropriate.

Dynamic Overload Protection

All SuperCAT4+ locators incorporate Dynamic Overload Protection, a powerful signal processing tool that identifies and automatically rejects electrical interference that may otherwise overload the locator's electronics. Dynamic Overload Protection allows the operator to locate pipes and cables in electrically noisy environments such as near power sub stations or near overhead high-voltage cables. Note that Dynamic Overload Protection will not overcome very high levels of interference. In this situation the Signal Overload Warning will appear (see Warnings).

Power and Radio mode location

Note: After completing a power mode sweep we recommend that you repeat the procedure in radio mode; the procedure is the same.

Power mode

Power mode detects power signals radiated by loaded power cables. To select Power mode, rotate the function switch until the LCD displays a P icon. Rotate the sensitivity control fully clockwise for maximum sensitivity but reduce if there is a blanket signal across the site. Define the excavation site and carry out a grid pattern sweep. Note that sometimes the signal may be re-radiated from other conductors.

Sweep the site holding the SuperCAT4+ upright at your side. Continue the sweep beyond the perimeter of the site. The presence of a buried conducting pipe or cable will be indicated by a tone emitted from the loudspeaker and a kick on the LCD's bar graph.

Keep the SuperCAT4+ blade vertical and move slowly backwards and forwards over the conductor. Reduce the sensitivity for a narrower response; this will allow you to pinpoint the conductor. With the SuperCAT4+ use the meter deflection to aid pinpointing. Maximum meter deflection and audible volume from the speaker will indicate the position of the conductor.

When directly over the conductor and with the sensitivity level set for a narrow response, rotate the SuperCAT4+ on its axis until the signal minimum is found. The blade is now parallel with the conductor.

Trace the conductor beyond the site and mark the position as required.

Radio Mode

Radio mode detects broadcast signals that originate from radio transmitters. These signals penetrate the ground and are re-radiated by buried conductors. However, depending on your location, these signals may not be present.

StrikeAlert™



The StrikeAlert feature warns the operator of shallow pipes and cables.

When a shallow cable or pipe is detected in Power or Active line Mode, StrikeAlert flashes an asterisk and sounds a distinctive warbling audio tone. StrikeAlert is not activated when tracing sondes or Radio signals.

T1 – 1W transmitter

The T1 is a general purpose, 1 Watt, transmitter that provides three locatable frequencies, two induction frequencies and two power levels. By default, the T1 induces a signal directly into the ground. It is the perfect companion to the SuperCAT4+ range of cable and pipe locators.

Transmitter features

- 1. On/Off/Frequency Selector.** LEDs indicate which frequency has been selected.
 - a. First press switches the transmitter on and selects the lowest locate frequency – depending on product specified. See T1 transmitter range table.



NOTE: the lowest frequency is only available for direct connections and will not work in induction mode.

- b. Second and third presses select the mid and highest frequencies.
 - c. Fourth press turns the transmitter off.
- 2. Power Selector**

Selects either high or low power level. LEDs indicate which power level is active.
 - 3. Accessory Socket**

Connects cables or optional accessories such as the Signal Clamp, Direct connection lead or Live Plug Connector. When connected, induction mode is disabled. A loudspeaker emits a pulsing tone to indicate sufficient battery charge and a satisfactory direct connection.
 - 4. Battery Access Panel.** When no tone is audible the batteries must be replaced.
 - 5. Arrows**

The arrows on the top panel label indicate the required transmitter alignment above the pipe or cable when using Induction mode. The arrows and the pipe or cable must be parallel. Alignment is not required when the T1 is in Active mode.

Note: Turn off the T1 and remove any cables or accessories before changing batteries.

Cable location using the T1 transmitter

The T1 transmitter is used to actively apply a locate signal to cables or metallic pipes. This signal can be traced using the locator in Active Line mode (L).

Use of the T1 is strongly recommended, as passive power or radio signals may not be present, or detectable, on all cables and pipes.

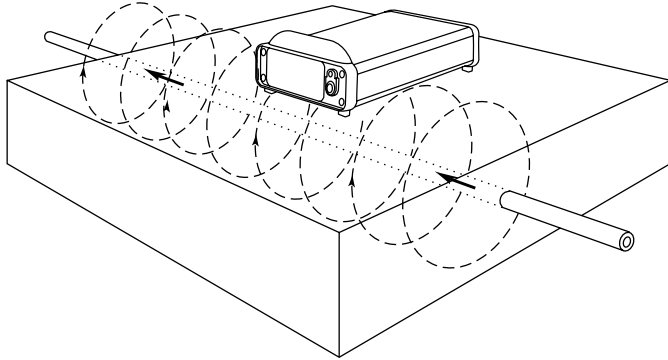

Induction mode

The T1 has an internal aerial that will induce a signal onto a line (or lines) directly below it. This is useful when you do not have direct access to the line. Generally, induction is only effective to depths of 2m (6'6"). Note that the induction mode is indiscriminate and will apply a signal to all conductors within its range.

Induction is only available with frequencies 8kHz and above.

Procedure

Place the transmitter over the approximate position of the underground utility with arrows pointing parallel to its path. Set the locator's sensitivity to 100% and start locating the line at least 10m (33 feet) away from the transmitter. Mark the ground when the locator detects any signal spike.

Note: Induction cannot apply a signal to a line below reinforced concrete.

Note: The locator may detect the transmitter signal directly from the T1 rather than the target line, so do not attempt depth measurements within 10 meters of the transmitter.

To check if you are detecting a signal from the T1, point the locator directly at the transmitter. If the locator's signal strength increases, either reduce the transmitter power or increase the distance between you and the transmitter. If the signal strength decreases, the signal is from the buried line.

Direct connection

⚠ Connection to a power cable sheath should only be undertaken by qualified personnel.

Direct Connection is an effective way to apply the T1 locate signal to a specific cable or pipe network so that it can be traced from above ground. Connections can be made to any metallic part of the pipe or cable such as valves, meters, junction boxes, street lights, pipeline markers or other access points.

Procedure

With the T1 switched off, plug the Direct Connect lead into the accessory socket. Attach the red lead to the pipe or cable (if necessary, clean the connection point to ensure a good electrical contact). If the jaws of the clip do not open far enough, and if the connection point is a suitable material, use the supplied magnet.

Connect the black lead to the earth stake which should be secured in the ground 3 – 4m away from, and at right angles to the target line.

Alternatively the black lead may be clipped to a valve box, manhole cover or another earthed point. Use the earth spool lead to extend the earth connection if necessary.

Switch the T1 on. A good connection is indicated by a drop in loudspeaker tone. If there is no tone replace the batteries.

Start with the T1's lowest power setting. A pulsed loudspeaker tone indicates a good connection. If there is no tonal change, check the electrical contacts and the ground. If necessary, change the position of the ground stake or pour water over the ground contact if placed in dry soil or sand. If there is still no change in tone increase the power setting.

Note: The locator can detect a signal many times weaker than what is necessary for a T1 tone change and short distances can be traced without a pulsed tone from the loudspeaker.

To remove the direct connection cable grip the black sleeve on the outside of the plug and ease off the connector.

⚠ Do not pull the wire as this may damage the cable and/or socket.

Regularly check your locator and T1, in all modes over a cable which provides a response that you are familiar with.

Signal Clamp (optional extra)

The optional Signal Clamps can be used to apply a T1 locate signal safely to a cable or pipe up to 215mm (8.5") in diameter without interrupting the supply. Signal clamps are not suitable for connecting around lamp posts.

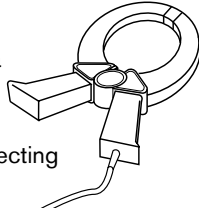

Procedure

With the T1 switched off, plug the Clamp lead into the accessory socket. Place the Clamp around the pipe or cable ensuring the jaws are completely closed.

Switch the T1 on, then open and close the Clamp. If the jaws are closing correctly there will be a change in tone as the jaws are closed.

An earth connection from the T1 is not necessary but optimal signal transfer is only generally achieved if the target line is grounded at both ends. This is usually the case with power cables.

⚠ WARNING! To avoid the risk of electric shock, the signal clamp must be connected to the transmitter before being placed around the pipe or cable.

Locating a sonde

The SuperCAT4+ locators are capable of locating a Radiodetection sonde. Before attempting to locate a sonde ensure that the sonde's batteries are fully charged. Radiodetection recommends using new or fully recharged batteries at the beginning of each day and preferably at the start of each job. Also check that the locator is operating at the same frequency as the sonde and that they are both working correctly.

To test the locator and the sonde, position the sonde at a distance equal to its rated depth range from the locator. Point the locator at the sonde with its blade parallel to the direction the sonde is travelling. Check that the bar graph shows more than 50% at high sensitivity.

Note: The blade of the locator must be in line with the sonde; this is the opposite to Active line locate method.

Procedure

1. Attach the sonde to the rod and insert it into the drain or duct to be mapped. Keep the sonde just in view.
2. Hold the locator vertically directly over the sonde with the blade in line with the sonde's orientation.
3. Adjust the sensitivity of the locator to give a bargraph reading between 60-80%.

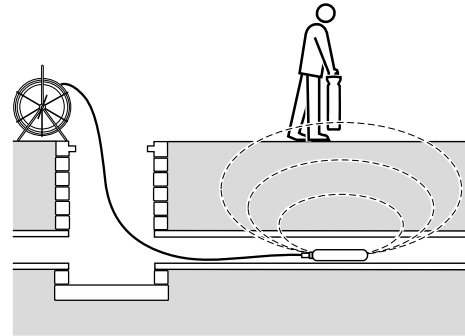

A sonde radiates a peak field from the center of its axis with ghost signals at each side of the peak. Move the locator to one side and then along the axis of the sonde forwards and backwards to detect the ghost signals.

Radiodetection recommends locating the ghost signals as finding them confirms the position of the main peak. To lose the ghost signals, reduce the sensitivity of the locator; this should leave only the main peak signal detectable.

With the locator sensitivity set as desired, propel the sonde along 1m (3-4 feet) and stop. Place the locator over the estimated position of the sonde and:

1. Move the locator backwards and forwards with the blade's orientation parallel to the sonde.
2. Stop when the bar graph indicates a clear peak.
3. Rotate the locator as if the blade were a pivot, stop when the display indicates a clear peak response.
4. Move the locator from side to side until the bar graph indicates a clear peak.
5. When the locator locates a peak signal, it will automatically calculate the depth of the sonde. Observe the depth reading while moving the locator from side to side; the lowest reading will be the correct location.

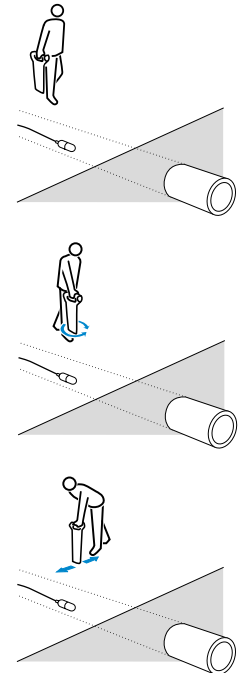

Repeat each step in smaller increments with the locator blade resting on or near the ground. The locator should now be directly above the sonde with the blade parallel with the sonde; mark this position.

Propel the sonde a further 1 m (3-4 feet) along the pipe and pinpoint and mark. Repeat the procedure along the route at similar intervals. Note, while tracking the sonde altering the locator's sensitivity is not required unless the depth of the pipe, or the distance between locator and sonde changes.

Measuring sonde depth

Pinpoint the sonde as previously described. Then rest the locator on the ground with the blade's orientation parallel to the orientation of the sonde. Adjust the sensitivity to give a meter reading of 60% to 80% on the LCD's bargraph.

Note that the depth reading is the distance from the bottom of the locator blade to the center of the sonde and not to the drain or duct being located.

CAUTION: Ensure Depth readings are taken from peak readings.

Depth readings taken from ghost signal position will be incorrect.

Depth measurement is automatic. Depth reading will be displayed when the locator is moved slowly across the sonde. The shallowest depth reading displayed on the LCD is also the correct position directly above the sonde.

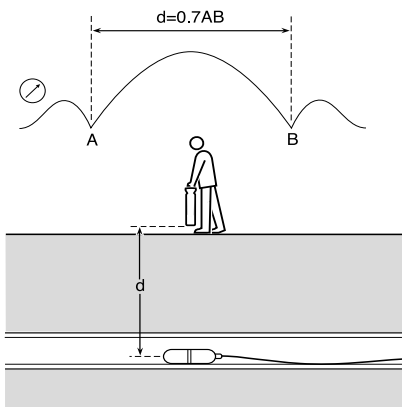

If the signal is too weak or unstable the locator unit will not calculate depth. In this case use a more powerful sonde or use the Pinpoint procedure described below.

Pinpoint Procedure.

1. Move the locator ahead of the sonde.
 - a. Ensure the blade's orientation is parallel with the sonde's orientation

- b. Increase the sensitivity slightly to find the ghost signal. Note that between the main peak and ghost there is a Null or minimum.

2. Mark the Null or minimum position for reference.
3. Now move behind the sonde and repeat step 1.
4. Find the Null between the ghost and main peak. See points A and B on the diagram.
5. The higher the sensitivity of the locator the sharper the Null's appear.
6. Measure the distance between points A and B and multiply by 0.7 to give an approximate depth measurement.

Warnings

Signal Overload

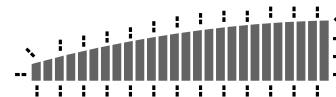

If the locator is used in areas where very large power signals are present, the signal bargraph will flash. In this condition the sensitivity control and depth function will not operate and you are advised to try lifting the locator to bring it out of the overloaded condition or use in a different location.

Deactivating

If required the StrikeAlert warnings can be temporarily disabled by pressing and holding the frequency selection button for the duration of the battery test bleep at switch on.

Live Plug Connector

⚠ Do not use the supplied Direct Connect leads to connect to live cables. Use the Radiodetection Live Plug Connector or Live Cable Connector. Failure to do so may result in injury or equipment damage.

⚠ Connection to live power cables should only be undertaken by qualified personnel.

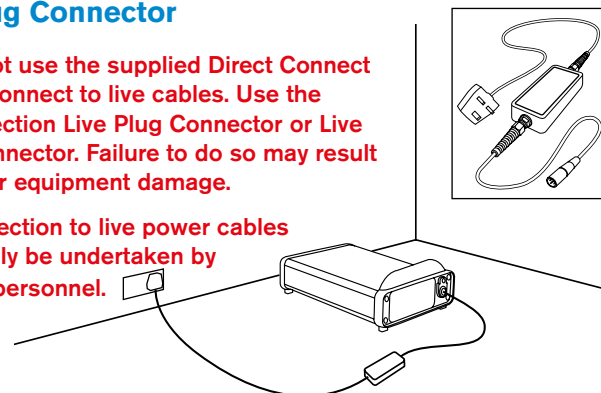

The optional Live Plug Connector applies the transmitter signal to a live domestic power socket and via the domestic wiring system on the service cable and the supply cable in the street. The signal should be detectable on the supply system to a few hundred meters each side of the point of application.

Note: Do not connect the transmitter to live cables without using a Live Plug Connector or Live Cable Connector.

Procedure

With the T1 switched off, connect the Live Plug Connector to the transmitter and then to the live domestic power socket. Where required switch on the power socket.

Note: The Live Plug Connector provides protection to 250V AC.

Sweep the site holding the locator upright at your side. Continue the sweep beyond the perimeter of the site. The presence of a buried conducting cable will be indicated by a tone emitted from the loudspeaker and a spike on the LCD's bar graph.

Keep the locator's blade vertical and move slowly backwards and forwards over the conductor. Reduce the sensitivity for a narrower response; this will allow you to pinpoint the conductor. With the locator use the meter deflection to aid pinpointing. Maximum meter deflection and audible volume from the speaker will indicate the position of the conductor.

When directly over the conductor and with the sensitivity level set for a narrow response, rotate the locator on its axis until the signal minimum is found. The blade is now parallel with the conductor.

Trace the conductor beyond the site and mark the position as required.

FlexiTrace™ – to locate non-metallic utilities

FlexiTrace is a 50m (164') or 80m (260') flexible conductive rod with a built-in sonde that can be inserted into non-metallic pipes and ducts to allow them to be located at depths of up to 3m (10') FlexiTrace can be inserted into a pipe or duct as small as 12mm (1/2") internal diameter, and with bends as tight as 250mm.

To use as a mouse, connect both transmitter leads to the FlexiTrace lugs. In this mode, only the tip of the FlexiTrace will be locatable. To trace the whole length, connect the red transmitter lead to a FlexiTrace terminal and ground the black lead, either to the earth stake or to an appropriate earthing point.

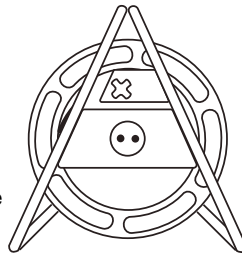

Service and Maintenance

⚠ SuperCAT4+ and the T1 transmitter are designed to require minimal recalibration. However, as with all safety equipment, it is recommended that they are serviced and have their calibration validated at least once a year using Radiodetection approved test equipment. Radiodetection accepts no responsibility for service, calibration or repairs carried out by non-authorised persons.

To check when the SuperCAT4+ is next due to be calibrated, squeeze the trigger, then press the depth button until 'C' (Configuration) is displayed. The display will now automatically step through the following information: 'S' (software version), 'D' (day), 'M' (month) and 'Y' (year).

Functional test

Radiodetection recommends that you perform a daily functional test on your locator and transmitter before use.

- Place the T1 on the ground, switch on and check for an audible sound. If no sound is heard, replace the batteries before use.
- Switch on the locator by squeezing the trigger, checking for an initial 'chirp.' A low tone indicates low batteries. If no sound is heard, replace the batteries before use.
- Rotate the locator function switch and check that the appropriate letter is displayed in each position of the switch.
- Set the locator and transmitter to the same active frequency. With the locator in Active Line mode (L), set the sensitivity at its maximum gain, hold at waist height pointing toward the T1 with the flattest part of the housing parallel to the ground and check that the SuperCAT4+ can detect the T1 up to 15m away with a clearly audible sound.

Replacing batteries

⚠ Do not mix new and old batteries or different types of batteries, as this may cause them to overheat.

SuperCAT4+

To replace batteries, open the access cover using a screwdriver or coin. Use two LR20 (D-cell) alkaline batteries or equivalent NiMH rechargeable batteries.

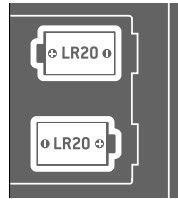

T1

To replace batteries, Unscrew fastener on the rear panel and replace with four LR20 (D cells) alkaline batteries. Observe correct battery polarity as indicated on the top-panel label.



Product specification

Locator Technical Specification				
Locate performance	Frequency range	Sensitivity @ 1m	Depth Good conditions	Depth Poor conditions
Power signals (P)	50Hz – 1.5kHz	3mA	3m	2m
Radio signals (R)	15kHz – 30kHz	25µA	2m	1m
T1 signals (L) ¹	512/640Hz 8 kHz 33 kHz 65 kHz 131 kHz	500 µA 100 µA 5 µA 5 µA 5 µA	4 m	2 m
Sonde (S) ¹	512Hz/640Hz/ 8kHz/33 kHz	N/A	Up to 15m	

¹Model dependent

Dynamic range	120dB @ 10Hz
Dynamic Overload Protection	40dB @ 50Hz (automatic)
Locate accuracy	± 10% of depth
Depth accuracy (on undistorted signal and with no adjacent signals)	Line: 5% 0.1 m to 3m (4 in to 10ft) Sonde: 5% 0.1 m to 7m (4 in to 16ft)

Operating temperature range	-20°C to +50°C (4°F to 122°F)
Storage temperature range	-20°C to 70°C (4°F to 158°F)
Environmental protection	IP54
Batteries	Locator: 2 x Alkaline or NiMH D-cells (LR20) Transmitter T1: 4 x Alkaline D-cells (LR20)
Data interface	USB 2.0 – for future use
Recommended service interval	1 year
Warranty	12 months from purchase
Unit Weight	Locator: 2.3 kg (5.1 lbs) (including batteries) Transmitter: 1.7 kg (3,8 lbs) (including batteries)

Warranty

Subject to the conditions set out herein, Radiodetection Limited expressly and exclusively provides the following warranty to original end user buyers of Radiodetection products.

Radiodetection hereby warrants that its products shall be free from defects in material and workmanship for one year starting from point of sale to end customer. Extensions of this warranty period may be available where the same terms and conditions apply.

Statement of warranty conditions

The sole and exclusive warranty for any Radiodetection product found to be defective is repair or replacement of the defective product at Radiodetection's sole discretion. Repaired parts or replacement products will be provided by Radiodetection on an exchange basis and will be either new or refurbished to be functionally equivalent to new.

In the event this exclusive remedy is deemed to have failed of its essential purpose, Radiodetection's liability shall not exceed the purchase price of the Radiodetection product. In no event will Radiodetection be liable for any direct, indirect, special, incidental, consequential or punitive damages (including lost profit) whether based on warranty, contract, tort or any other legal theory.

Warranty services will be provided only with the original invoice or sales receipt (indicating the date of purchase, model name and dealer's name) within the warranty period. This warranty covers only the hardware components of the Radiodetection product.

Before a unit is submitted for service or repair, under the terms of this warranty or otherwise, any data stored on the unit should be backed-up to avoid any risk of data loss. Radiodetection will not be responsible for loss or erasure of data storage media or accessories.

Radiodetection is not responsible for transportation costs and risks associated with transportation of the product. The existence of a defect shall be determined by Radiodetection in accordance with procedures established by Radiodetection.

This warranty is in lieu of any other warranty, express or implied, including any implied warranty of merchantability or fitness for a particular purpose.

This warranty does not cover:

- a. Periodic maintenance and repair or parts replacement due to wear and tear.
- b. Consumables (components that are expected to require periodic replacement during the lifetime of a product such as non rechargeable batteries, bulbs, etc.).

- c. Damage or defects caused by use, operation or treatment of the product inconsistent with its intended use.
- d. Damage or changes to the product as a result of:
 - i. Misuse, including: - treatment resulting in physical, cosmetic or surface damage or changes to the product or damage to liquid crystal displays.
 - ii. Failure to install or use the product for its normal purpose or in accordance with Radiodetection instructions on installation or use.
 - iii. Failure to maintain the product in accordance with Radiodetection instructions on proper maintenance.
 - iv. Installation or use of the product in a manner inconsistent with the technical or safety laws or standards in the country where it is installed or used.
 - v. Virus infections or use of the product with software not provided with the product or incorrectly installed software.
 - vi. The condition of or defects in systems with which the product is used or incorporated except other 'Radiodetection products' designed to be used with the product.
 - vii. Use of the product with accessories, peripheral equipment and other products of a type, condition and standard other than prescribed by Radiodetection.
 - viii. Repair or attempted repair by persons who are not Radiodetection warranted and certified repair houses.
 - ix. Adjustments or adaptations without Radiodetection's prior written consent, including:
 - i. upgrading the product beyond specifications or features described in the instruction manual, or modifications to the product to conform it to national or local technical or safety standards in countries other than those for which the product was specifically designed and manufactured.
 - x. Neglect e.g. opening of cases where there are no user replaceable parts.
 - xi. Accidents, fire, liquids, chemicals, other substances, flooding, vibrations, excessive heat, improper ventilation, power surges, excess or incorrect supply or input voltage, radiation, electrostatic discharges including lightning, other external forces and impacts.

Copyright © 2017 Radiodetection Ltd. All rights reserved. Radiodetection is a subsidiary of SPX Corporation. Radiodetection, SuperCAT, SuperCAT4+, StrikeAlert, eCert are trademarks of Radiodetection in the United Kingdom and/or other countries. The Bluetooth word, mark and logos are registered trademarks of Bluetooth SIG, Inc. and any use of such trademarks by Radiodetection is under license. Due to a policy of continued development, we reserve the right to alter or amend any published specification without notice. This document may not be copied, reproduced, transmitted, modified or used, in whole or in part, without the prior written consent of Radiodetection Ltd.



Visit www.radiodetection.com

Global locations

Radiodetection (USA)

28 Tower Road, Raymond, Maine 04071, USA

Tel: +1 (207) 655 8525 Toll Free: +1 (877) 247 3797 rd.sales.us@spx.com

Pearpoint (USA)

39-740 Garand Lane, Unit B, Palm Desert, CA 92211, USA

Tel: +1 800 688 8094 Tel: +1 760 343 7350

pearpoint.sales.us@spx.com www.pearpoint.com

Radiodetection (Canada)

344 Edgeley Boulevard, Unit 34, Concord, Ontario L4K 4B7, Canada

Tel: +1 (905) 660 9995 Toll Free: +1 (800) 665 7953 rd.sales.ca@spx.com

Radiodetection Ltd. (UK)

Western Drive, Bristol, BS14 0AF, UK

Tel: +44 (0) 117 976 7776 rd.sales.uk@spx.com

Radiodetection (France)

13 Grande Rue, 76220, Neuf Marché, France

Tel: +33 (0) 2 32 89 93 60 rd.sales.fr@spx.com

Radiodetection (Benelux)

Industriestraat 11, 7041 GD 's-Heerenberg, Netherlands

Tel: +31 (0) 314 66 47 00 rd.sales.nl@spx.com

Radiodetection (Germany)

Groendahlscher Weg 118, 46446 Emmerich am Rhein, Germany

Tel: +49 (0) 28 51 92 37 20 rd.sales.de@spx.com

Radiodetection (Asia-Pacific)

Room 708, CC Wu Building, 302-308 Hennessy Road, Wan Chai,

Hong Kong SAR, China Tel: +852 2110 8160 rd.sales.asiapacific@spx.com

Radiodetection (China)

13 Fuqianyi Street, Minghao Building D304, Tianzhu Town, Shunyi District,

Beijing 101312, China Tel: +86 (0) 10 8146 3372 rd.service.cn@spx.com

Radiodetection (Australia)

Unit H1, 101 Rookwood Road, Yagoona NSW 2199, Australia

Tel: +61 (0) 2 9707 3222 rd.sales.au@spx.com

Copyright © 2017 Radiodetection Ltd. All rights reserved. Radiodetection is a subsidiary of SPX Corporation. Radiodetection, SuperCAT, SuperCAT4+, StrikeAlert, eCert are trademarks of Radiodetection in the United Kingdom and/or other countries. The Bluetooth word, mark and logos are registered trademarks of Bluetooth SIG, Inc. and any use of such trademarks by Radiodetection is under license. Due to a policy of continued development, we reserve the right to alter or amend any published specification without notice. This document may not be copied, reproduced, transmitted, modified or used, in whole or in part, without the prior written consent of Radiodetection Ltd.