

EZiSYSTEM User Manual



Version 1.0
English

Introduction

Purchase

Congratulations on your purchase of an EZiSYSTEM instrument.



Product identification

This manual contains important safety directions as well as instructions for setting up the product and operating it. Refer to "9 Safety Directions" for further information. Read carefully through the User Manual before you switch on the product.





The model and the serial number of your product are indicated on the type plate. Enter the model and serial number in your manual and always refer to this information when you need to contact your agency or Cable Detection authorised service workshop.

Type: _____

Serial No.: _____

Symbols

The symbols used in this manual have the following meanings:

Type	Description
 Danger	Indicates an imminently hazardous situation which, if not avoided, will result in death or serious injury.
 Warning	Indicates a potentially hazardous situation or an unintended use which, if not avoided, could result in death or serious injury.
 Caution	Indicates a potentially hazardous situation or an unintended use which, if not avoided, may result in minor or moderate injury.
	Important paragraphs which must be adhered to in practice as they enable the product to be used in a technically correct and efficient manner.

Validity of this manual

This manual applies to all EZiSYSTEM instruments, which are the i-Series locators, the t-Series transmitters and accessories. Differences between the various instruments and models are marked and described.

Table of Contents

In this manual	Chapter	Page
	1 General Information	7
	1.1 How to Use this Manual	7
	1.2 i-Series General Information	8
	1.3 i-Series Instruments and Accessories	10
	2 How to Use the Locator	11
	2.1 General Information	11
	2.2 Locator Overview	13
	2.3 Locator Setup and Information	16
	2.4 Hazard Zone	19
	2.5 How to Locate a Service	21
	2.6 Wireless Data Communication, where applicable	34
	2.7 Memory & Communication	37
	2.8 Internal GPS	38
	3 How to Use the Transmitter	40
	3.1 General information	40
	3.2 Transmitter Overview	42
	3.3 How to Locate a Service Using the Transmitter	45
	4 How to Use the Conductive Rod	49
	4.1 General Information	49
	4.2 Conductive Rod Overview	49
	4.3 How to Locate a Service Using the Conductive Rod	50

5	How to Use the Signal Clamp	52
5.1	General Information	52
5.2	Signal Clamp Overview	52
5.3	How to Locate a Service Using the Signal Clamp	53
6	How to Use the Property Connection Set	55
6.1	General Information	55
6.2	Property Connection Set Overview	55
6.3	How to Locate a Service Using the Property Connection Set	56
7	How to Use the Sonde	58
7.1	General Information	58
7.2	Sonde Overview	58
7.3	How to Locate a Service Using the Sonde	61
8	Care and Transport	63
8.1	Transport	63
8.2	Storage	63
8.3	Cleaning and Drying	64
9	Safety Directions	65
9.1	General Introduction	65
9.2	Intended Use	65
9.3	Limits of Use	66
9.4	Responsibilities	66
9.5	Hazards of Use	67
9.6	Electromagnetic Compatibility EMC	72
9.7	FCC Statement, Applicable in U.S.	75

10	Technical Data	80
10.1	Locator i-Series Technical Data	80
10.2	Transmitter Technical Data (1 Watt models)	85
10.3	Conductive Rod Technical Data	88
10.4	Sonde Technical Data	90
10.5	Property Connection Set Technical Data	92
10.6	Signal Clamp Technical Data	94
11	International Limited Warranty	96
Appendix A	Functional Checks	97
A.1	Locator Functional Check	97
A.2	Transmitter Functional Check	101
A.3	Conductive Rod Functional Check	107
A.4	Sonde Functional Check	109
Appendix B	World Frequency Zones	112
Index		116

1

1.1



Naming convention

General Information

How to Use this Manual

It is recommended to set up the product while reading through this manual.

EZiCAT i500, i550, i600, i650, i700, i750 and xf models are hereinafter referred to as Locator. Differences between the models are marked and described.

EZITEX t100, t300 and xf models is hereinafter referred to as Transmitter.

EZiROD is hereinafter referred to as Conductive Rod.

Index

The index is at the back of the manual.

Instrument label

On the Locator and Transmitter you will find a label that shows some important information by means of illustrations. You will find some of these illustrations in this manual too. This should help to get a clear connection between the instrument label and the information in this manual.

1.2

i-Series General Information

Description

Locators are used to detect buried conductive services emitting an electromagnetic signal which is generated by a current passing through the service.

Transmitters are used to apply a distinct signal to conductive services, which may not radiate electromagnetic signals or may need to be traced for a specific purpose. The Transmitter is required to make a depth or current measurement.

The Locators and Transmitters described within this manual will greatly increase the detection process and help to reduce the dangers and costs associated with service strikes. But the very nature of electromagnetic location is dependent on the services being conductive (metallic) and radiating a signal as current flows through them.

It is important to remember that a Locator on its own will not detect all services and care should be taken when excavating. It is generally accepted that a safe system of work should be adopted which would include planning the work in advance, the use of utility maps, the use of Locators and Transmitters, and the use of safe digging practices.

Caution

The absence of a positive indication does not guarantee the non-existence of a service. Services without a detectable signal may be present.

The Locators can only locate non-metallic services such as plastic pipes, typically used by the water and gas utilities, with the use of appropriate accessories.

Precautions:

Always excavate with care.

Accessories

Designed to increase the detection of services with no (or little) signals on them. Generally work in conjunction with the Locator and Transmitter.

Functional Check

Designed to demonstrate the equipment is working satisfactorily in between service intervals. Refer to "Appendix A Functional Checks" for more information.

1.3

i-Series Instruments and Accessories

General information

The i-Series is a collection of products used to locate buried metallic and nonmetallic services.

i-Series instruments overview

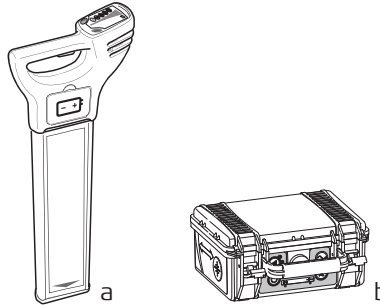

- a) Locator
- b) Transmitter

i-Series accessories overview

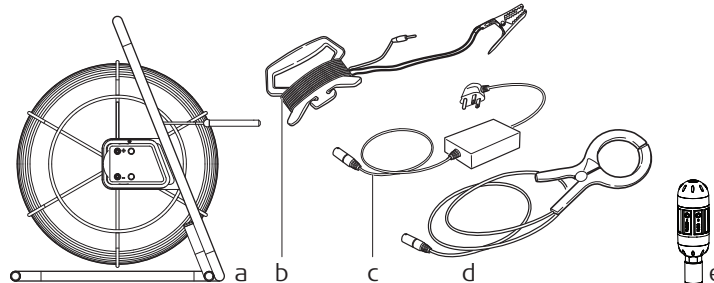

- a) Conductive Rod (non metallic service tracer)
- b) Extension Cable
- c) Property Connection Set
- d) Signal Clamp
- e) Sonde

2

How to Use the Locator

2.1

General Information

Operating modes

- Passive modes: Power and Radio
 - Active modes: 8 kHz, 33 kHz, additionally 512 Hz and 640 Hz on xf models
 - Auto mode: Combined Power and Radio modes
-

Electromagnetic signals

An electromagnetic signal radiates from buried conductive services as an electrical current flows through them. The Locator processes these signals and displays their presence.

Passive signals

Some signals are already present on buried services and can be readily detected by the Locator. We call these passive signals. These signals are generated by power distribution systems and radio transmitters.

Active tracing

Some conductive services do not emit passive signals. These services may be traced by applying a signal to the service by using a transmitter.

Depth indication (i550, i650, i750, i550xf, i650xf, i750xf)

Depth indication is only available with the **i550, i650, i750, i550xf, i650xf, i750xf** locators when used in conjunction with the Transmitter or Sonde. The displayed depth is to the centre of the service or to the Sonde.

Current Measurement (i550xf, i650xf & i750xf)

Current measurement is only available on the **i550xf, i650xf** or **i750xf** when used in conjunction with the transmitter. The highest current reading (mA) will be displayed over the service which has the transmitter connected to it.

Wireless communication (Bluetooth)

Data can be wirelessly transferred from the Bluetooth enabled Locator to devices which are designed to accept the information.

Hazard zone	Provides an additional alarm, indicating the close proximity of a service emitting a Power, 8 kHz, 33 kHz (512 Hz and 640 Hz on xf models) signal.
Peak hold	Assists in pinpointing a service by displaying the peak reading for a short period of time.

2.2

Locator Overview

Locator main parts

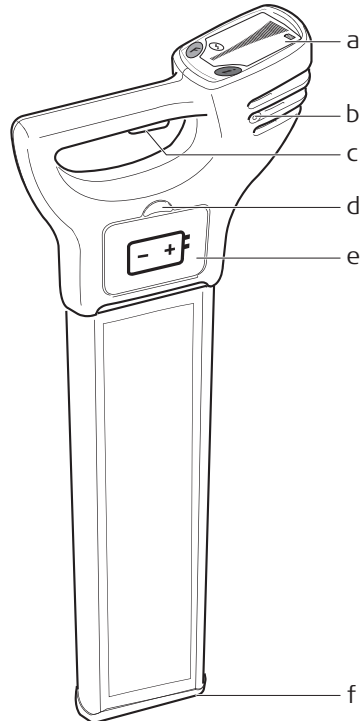

- a) **Display Panel**
Contains the operational controls.
- b) **Speakers** (mounted internally left and right)
Active at power on and when a signal is detected.
- c) **On/Off Trigger**
Press and hold the trigger to activate the Locator.
Release the trigger to deactivate.
- d) **Battery Hatch Release**
Pressing the release button unlocks the battery hatch allowing access to the battery compartment.
- e) **Battery Compartment**
6 x LR6 (AA) alkaline batteries are used. Replace all batteries when indicated.
- f) **Case Foot**



The case foot can be replaced if it is worn. Contact your agency or Cable Detection authorised service workshop.

Display panel overview

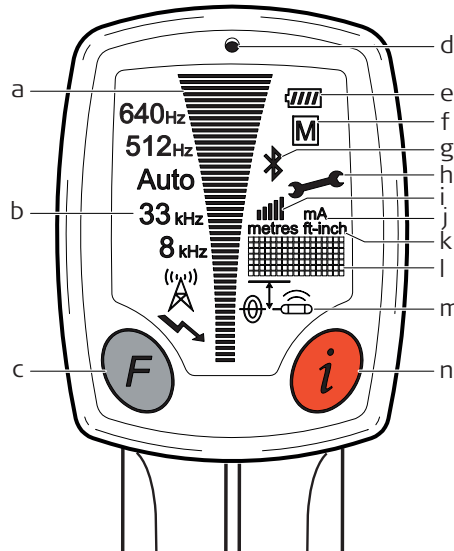

- a) **Signal Strength Indicator**
Indicates the response of the Locator to a signal (service).
- b) **Mode Indicators**
Displays the selected mode: Power, Radio, 8 kHz, 33 kHz, Auto, (512 Hz and 640 Hz on xf models). As shown, from bottom to top.
- c) **Function Button**
Selects operating mode.
- d) **Light Sensor**
Automatically switches the displays backlight on or off to suit light conditions.
- e) **Battery Indicator**
Indicates the battery condition. Segment illumination decreases as battery condition declines. Replace the batteries when the battery indicator is empty.
- f) **M Indicator**
Symbol Static: Memory enabled
GPS indicator (i700, i750, i750xf)
Symbol Flashing: GPS active and recording GPS coordinates.
Symbol Static: No GPS position.
- g) **Bluetooth Status Indicator**
Symbol Static: Bluetooth is enabled
Symbol Flashing: Bluetooth is paired
No Symbol: Bluetooth is disabled
- h) **Wrench**
Indicates the Locator requires periodic service or unit is faulty.

- i) **Numeric Signal Strength Indicator (SSI)**
Symbol Static: SSI is enabled
No Symbol: SSI is disabled
 - j) **Current Indicator (i550xf, i650xf and i750xf)**
Indicates the amount current flowing through a service which is applied by the Transmitter. This is measured in milliampères (mA).
 - k) **Measurement Unit** (Depth indication with the i550, i650, i550xf, i650xf and i750xf)
Indicates depth indication is in metric or feet and inches.
 - l) **Display Readout**
Alpha numeric matrix indicates system set up and depth indication.
 - m) **Depth Mode Indicators**
Indicates a depth reading to a service or a Sonde (Depth locators only). Service depth icon used to indicate Hazard Zone status.
 - n) **i Button**
Used to access the user settings and to provide a depth readout for Depth locators.
-

2.3

Locator Setup and Information

Locator settings

The i-Series Locators offer a range of settings which the operator can adjust to their own preference. It also displays additional service and contact information as detailed.

Setting	Description
EST	Performs a function check on the locators hardware and software, displaying PAS if the Locator is within predefined tolerance or ERR if the locator is not.
H.Z	Switches hazard zone on or off.
VOL	Adjust volume level (0 - 10).
HLD	Adjust peak hold duration (0 - 5 seconds).
SSI	Displays a numeric signal strength indicator.
CST	Adjusts display's contrast (0 - 15).
M/I	Displays unit of measurement.
CAL	Displays the next service date DD/MM/YY.
CON	Displays supplier/company name.
TEL	Displays supplier/company telephone number.
I.D	Displays the operator's name.
PWR	Displays the power mode regional setting. Refer to "Appendix B World Frequency Zones" for more information.
SR#	Displays unit serial number.
VER	Displays software version.
CLK (i600, i650, i700, i750, i600xf, i650xf, i750xf)	Displays the date and time held within the locators memory. Format DD/MM/YY/HH/MM/SS.

Setting	Description
LOG (i600, i650, i700, i750, i600xf, i650xf, i750xf)	Displays the last stored log number 001 to 999.
BT (i600, i650, i600xf & i650xf)	Adjusts the Bluetooth output options.
Setting COM (i700, i750 & i750xf)	Adjusts the locators Bluetooth or GPS settings: PC: Enables Bluetooth communication to Logicat Software BT1: Enables Bluetooth option 1 (refer to section 2.6) BT2: Enables Bluetooth option 2 (refer to section 2.6) GPS: Switches GPS on following use with BT1 or BT2 settings
LST (xf models)	Sets the Locators start up mode. On: The Locator starts in the last mode of operation used. Off: The Locator starts in Power mode.

Accessing and adjusting the settings

1. Switch the Locator on.
2. Ensure the Locator is in Power mode.
If required, press Function Button to select mode.
3. Depress the i Button until the user settings are displayed in the display readout.
4. Press Function Button to toggle through to desired setting.
5. Press i Button to select the setting.
6. Press Function Button to activate/adjust.
7. Press i Button to store and exit.

⚠ Danger

The Locator may fail to detect electrical services in Power mode if an incorrect power setting is used.

Precautions:

Before use, verify the Locator is setup to be compatible with mains frequency supply in your country. Options are 50 or 60 Hz. Refer to "Appendix B World Frequency Zones" for more information.

Contact your agency or Cable Detection authorised service workshop if your unit is incorrectly configured for your region.

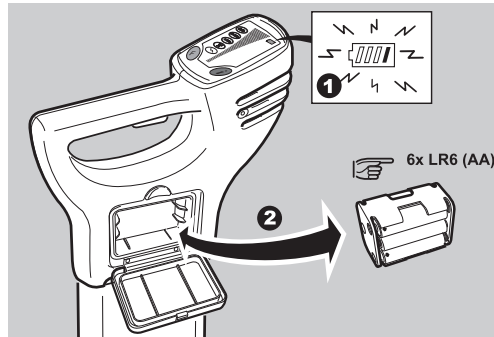
Changing the battery

1. Replace or Recharge the batteries when the battery status indicator is empty.
2. Press the release button to unlock the Battery Hatch. Remove the battery holder from the Locator.
3. Replace all batteries with six new LR6 (AA) type alkaline batteries, or remove and recharge the battery pack if rechargeable batteries are fitted.

2.4



Hazard Zone

Description

Provides an additional warning to the close proximity of buried services and functions in the following modes:

- Power
- 8 kHz
- 33 kHz
- Auto mode (Power mode only)
- 512 Hz & 640 Hz (xf models only)

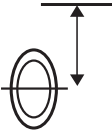
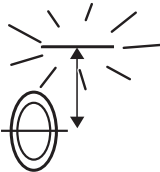
Hazard zone status indicators

Status indicator	Description
	Hazard zone is switched on.
	Hazard zone on and is alarming.
	Hazard zone is switched off.

 **Caution**

The absence of a positive indication does not guarantee the non-existence of a service. Services without a detectable signal may be present.

The Locators can only locate non-metallic services such as plastic pipes, typically used by the water and gas utilities, with the use of appropriate accessories.

Precautions:

Always excavate with care.

2.5

How to Locate a Service

Start up test

The following test sequence will take place every time the Locator is activated.

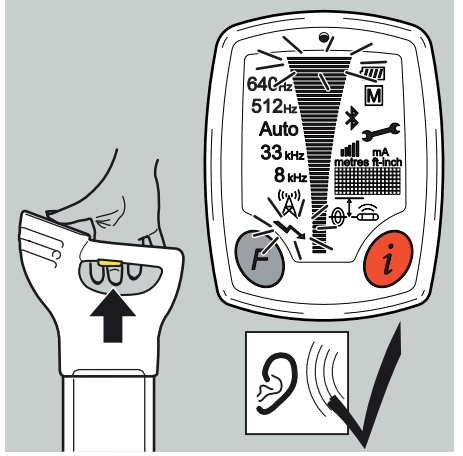
On test	Test pattern	Info on label
Audio Output	On throughout test sequence	
Signal Strength indicator	Scrolls through in sequence once	
Mode indicators	Briefly illuminated	
Indicator Icons	Briefly illuminated	
Battery indicator	On throughout test sequence	

GPS Search Mode (i700, i750 & i750xf)

A GPS search mode is activated as part of the start up test allowing the internal GPS module time to search for a GPS position. GPS search mode is active following the start up test even if the locator is off, the search mode will stop when a GPS position is obtained or a 12 minute search period has elapsed.

GPS search mode does not affect the locators performance and the locator can be used as normal throughout this search mode.

Locating process

The locating process is split into three steps:

- Sweep Search
- Pinpointing the service
- Direction of the service

Sweep Search

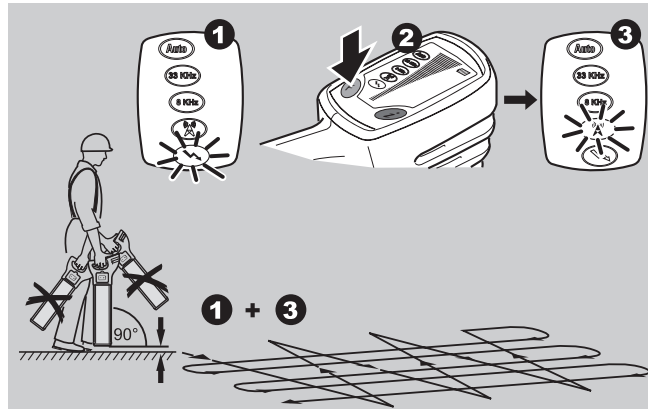

Auto mode combines the benefit of simultaneous detection in Power and Radio modes and helps to confirm the presence of services upon initial site occupation. Improved definition of the service will be provided by single mode operation.

Define the area to be excavated.

1. In Power mode cross the site from left to right keeping the Locator upright, taking care not to swing the unit. Turn through 90 degrees and repeat.



Ensure that the Locator is held in an upright position and close to the ground.

2. Continue the sweep until either a signal is located or you are satisfied that the area has been adequately tested.



In the presence of a service emitting a traceable signal a tone will be emitted and the signal strength indicator will rise and fall as you pass over it.

3. Repeat the Sweep Search process in Radio mode.

- ☞ The Sweep Search must be conducted in Power and Radio modes as a minimum, as not all services (including some electrical ones) emit a power signal. These services may be found using Radio mode or active modes.
- ☞ Hazard zone can be operated in Power, 8 kHz, 33 kHz and Auto (512 Hz and 640 Hz on xf models) modes and provides an additional alarm to the presence of buried services which may be within close proximity.

Pinpointing the service

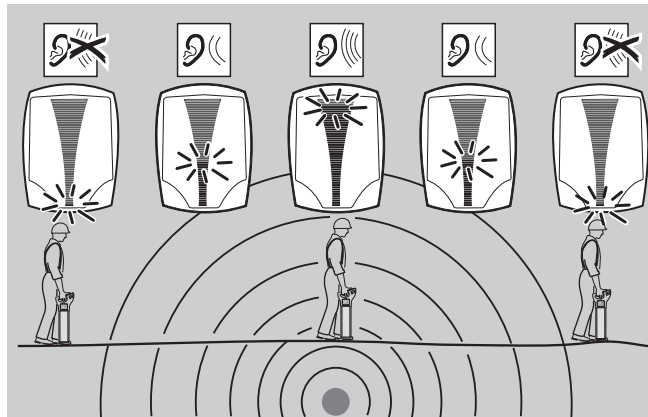

Retrace your steps to the area where the highest signal reading (peak response) was obtained. The service is directly below the Locator when the signal strength indicator is at its maximum. The audio output will automatically adjust to facilitate pinpointing over the service, and automatically reset when the signal strength indicator drops to its minimum position.



- Mark services with marker paint, pegs, flags or similar. **Never** drive pegs into the ground over the service.
- The signal strength indicator does not indicate the size, depth or type of a service.

Peak hold

When activated peak hold will show the highest peak reading obtained during the pinpoint process. The displayed reading can be adjusted between 0 to 5 seconds.

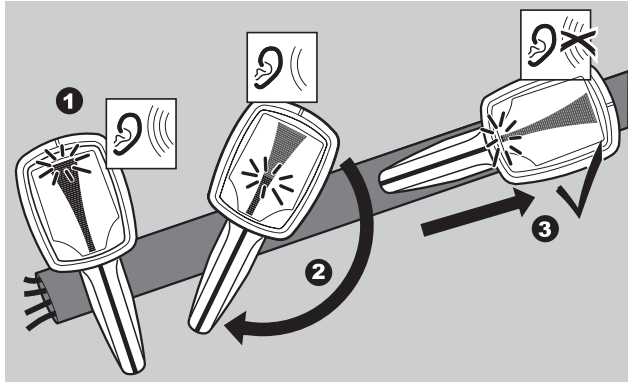
Detecting direction of the service

1. Position the Locator directly over the service.
2. Rotate the Locator on its axis.
3. The blade of the Locator will be in line with the service when the signal strength indicator is at its minimum.

Depth Indication (i550, i650, i750, i550xf, i650xf and i750xf)

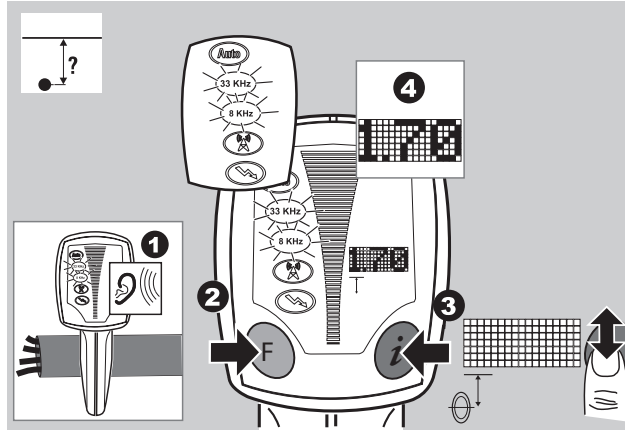

1. Apply a signal to the service. Refer to "3 How to Use the Transmitter" for more information.
2. Select the mode to suit the Transmitter's output. Position the Locator directly over, and at 90 degrees to the direction of the service.
3. Press and release the i Button.
4. The display readout will indicate the depth of the service and the Line mode icon will be displayed.

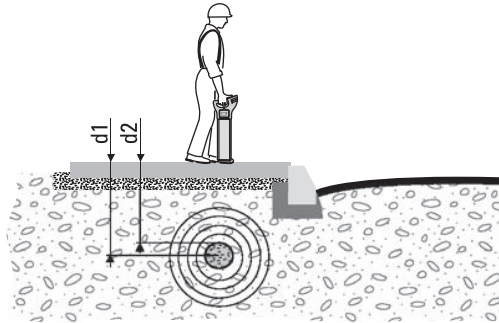

- Activating Sonde depth will provide an inaccurate readout.
- Mark utilities with marker paint, pegs, flags or similar. **Never** drive pegs into the ground over the service
- Additional services may be within the excavation zone, as well as the service you are taking a depth reading from.
- The reading will be more accurate when taken over a straight run, where the service does not bend, or have a service crossing it or coming off it.
- An additional depth reading should be taken with the locator lifted off the ground by approximately 100 mm (4 inches). The reading obtained should confirm the addition of this height.

Depth shown and actual depth:

$d1$ Depth shown on the EZiCAT = depth to the centre of the line.

$d2$ Actual depth of the service.

Note the difference between $d1$ and $d2$!

Warning

The depth reading might not reflect the real depth if your Locator picks up the signal induced into the service by the Transmitter. This signal is radiated from the centre of the service.

This is even more important when the signal is produced by a Sonde, lying in a large diameter conduit!

Precautions:

Always compensate depth reading for service size.

Measuring Sonde depth (i550, i650, i750, i550xf, i650xf and i750xf)

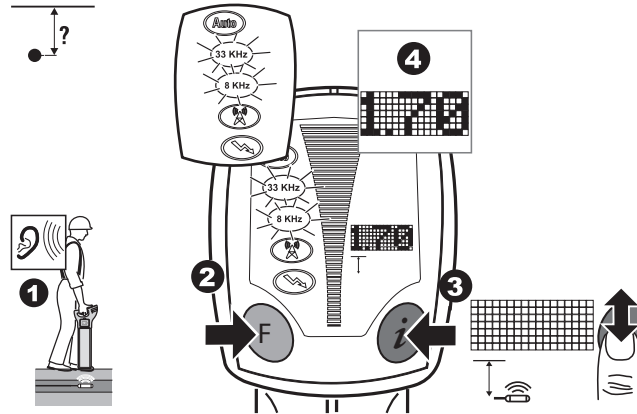

1. Switch on the sonde and set to the required frequency. Refer to "7 How to Use the Sonde" for more information.
2. Select the mode to suit the Sonde's output. Position the Locator directly over, and in line with the Sonde. Refer to "7 How to Use the Sonde" for more information.
3. Press and hold down the **i** Button for 2 seconds until the dashed lines have scrolled through once.
4. The display readout will indicate the depth of the Sonde and the Sonde mode icon will be displayed.



- Activating line depth will provide an inaccurate readout.
- Mark utilities with marker paint, pegs, flags or similar. **Never** drive pegs into the ground over the service.
- Additional services may be within the excavation zone, as well as the service you are taking a depth reading from.
- An additional depth reading should be taken with the locator lifted off the ground by approximately 100 mm (4 inches). The reading obtained should confirm the addition of this height.

Depth shown and diameter:

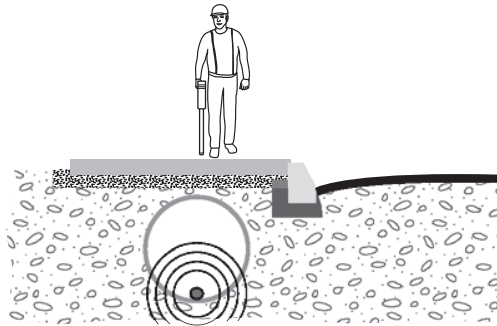

Take special care when the signal is produced by a sonde, lying in a large diameter conduit!







Warning

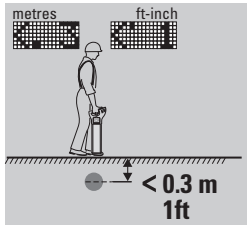
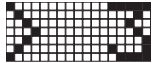

The depth reading may not indicate the real depth of the service, especially if the sonde is lying at the base of a large diameter duct.

Precautions:

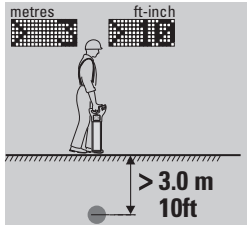
Always compensate depth reading for service size.

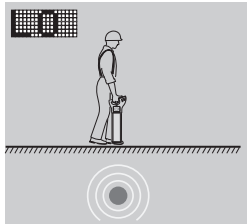
Depth code information

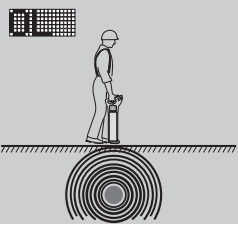
Information code	Description	Information on instrument label
 metres  ft-inch	<p>The service is too shallow to register properly.</p>	
 metres  ft-inch	<p>The service is too deep.</p>	
	<p>The signal received by the Locator is too small to register properly.</p>	

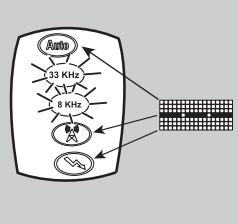
Information code	Description	Information on instrument label
	<p>The signal received by the Locator is too large to register properly.</p>	
	<p>Depth function not available. The Locator is set to the wrong mode for a depth reading to be taken.</p>	

Current Measurement (i550xf, i650xf and i750xf)

Current Measurement is used to identify the service to which the transmitter is attached, this is measured in milliamperes (mA).

The transmitter is used to apply a signal (current) to the required service. The signal can also couple to additional services making it hard to distinguish by conventional locating techniques.

The highest current reading (mA) will be obtained when the locator is positioned over the service which has the transmitter attached to it.

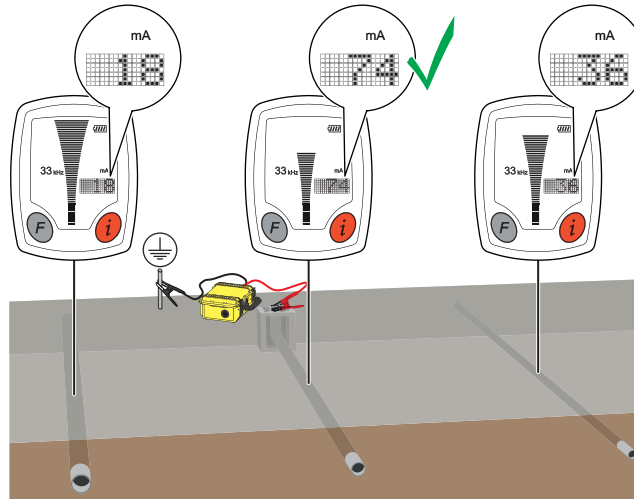

Additional information on the condition and layout of the service can be ascertained such as a fault in the service, damage to the insulation, or a connection off the service, these are typically indicated by sudden reduction in the current reading.

The signal (current) applied by the transmitter decreases at a uniform rate as it travels along the service. This can help to identify the service layout, as connections off it have a corresponding reduction in current. A sudden reduction in current may indicate damage to the service.

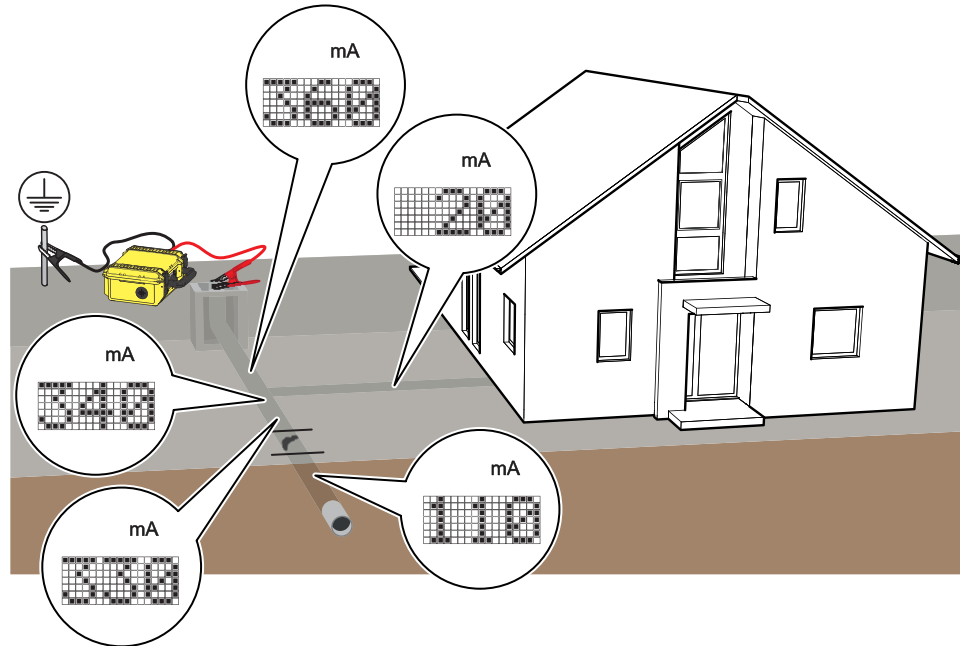

Taking a Current Measurement

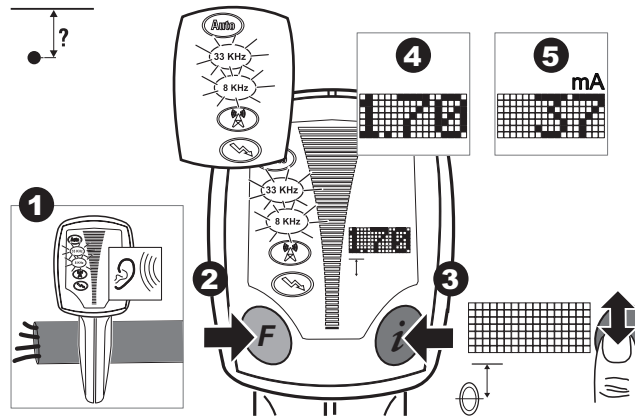

1. Apply a signal to the service. Refer to "3 How to Use the Transmitter" for more information.
2. Select the mode to suit the transmitters output. Position the Locator directly over, and at 90 degrees to the direction of the service.
3. Press and release the i Button.
4. The display readout will indicate the depth of the service and the Line mode icon will be displayed.
5. The display readout will then indicate the Current Reading.

2.6

Wireless Data Communication, where applicable

Bluetooth

Bluetooth status is indicated on the locators display, the Bluetooth symbol will be illuminated when Bluetooth connectivity is available. Data can be wirelessly transferred from a Bluetooth enabled Locator to a suitable data logging device, enabling the operator to capture information about the Locator's status and the service depth. When the Locator is paired to a suitable device, the Bluetooth symbol will flash, and the unit will transmit data periodically.

Important information for pairing:

- The Locator must be switched on throughout the process
 - Follow the instructions on the device for pairing. Refer to the manufacturer's instructions.
-

Pairing information

Locator Name: 'Model Number' - 'Serial Number'
for example: 550-000001

Pass key: 12345



- The Bluetooth symbol will flash continually when the devices have successfully paired.
 - When a depth reading has been taken, the Locator will display **LOG**. To transfer the information to the data logger press the **i** Button whilst **LOG** is displayed.
 - Whilst the Locator is calculating depth the data output stops.
 - If there is no wireless communication then the LOG function will not be displayed and the unit will function as a Locator.
 - The Locator will output ASCII text.
Refer to "ASCII text description" for more information.
-

ASCII text description

ASCII output pattern:

- BT1 (standard on all Bluetooth enabled locators):
DVxxxSNxxxxxxSVxxxTMxxxxDTdd/mm/yyCMxxSTxBTxMDxSSxxUMxDPxxxx
- BT2 (model dependent):
DPxxxxUMxMDxSSxxDVxxxSNxxxxxxCMxxBTxSTxSVxxxDTxxxxxxxxTMxxxx

Data output	Range	Example value	Description
DV	000 to 999	550	Model identifier
SN	000000 to 999999	123456	Serial number
SV	0.00 to 9.99	3.01	Software version
TM	00:00 to 23:59	08:30	Time: hh:mm (default = 00:00; no RTC fitted)
DT	00/00/00 to 31/12/99	01/12/10	Date: dd/mm/yy (default = 00/00/00; no RTC fitted)
CM	00 to 15	12	Number of months until next calibration (00 to 15)
ST	0 or 1	0	Self test: 0 = Pass, 1 = Fail
BT	0 to 9	7	Battery level: 0 = Empty, 9 = Good
MD	0 to 6	3	Mode: 0 = Power, 1 = Radio, 2 = 8 kHz, 3 = 33 kHz, 4 = Auto, 5 = 512 Hz, 6 = 640 Hz
SS	01 to 48	16	Signal strength: 01 to 48
UM	M or I	M	Units of measurements: M or I (Metres or Imperial)
DP	0.30 to 3.00 or ---	125	Depth value displayed depends on value for UM.

2.7

Memory & Communication

Data Records

The i600, **i650**, i700, i750, **i600xf**, i650xf and i750xf locators record and store information whilst they are in use. The locators start to record information every second after completion of the initial start-up routine. These records (logs) are stored in the locator's memory and can be retrieved and transferred via Bluetooth to a PC for analysis.



The records are sequentially stored, once the locator's memory is full the oldest records will be overwritten.



A communication pack is available from an authorised supplier, enabling users to retrieve the locators stored log files. We recommend you to install and use the Bluetooth Adapter & Logicat Software provided in the communication pack.

2.8

Internal GPS

Data Records

The i700, i750, i750xf locators have an internal GPS module which is used to record the geographical position of use. The geographical position (Latitude and Longitude) is stored in the log file and provides information on where the locator was used.

The **M** icon is used to display the GPS status as follows:

M flashing: GPS fix available and the geographical position is being recorded to the locators log files.

M static: No GPS fix and the geographical position is not being recorded to the locators log files

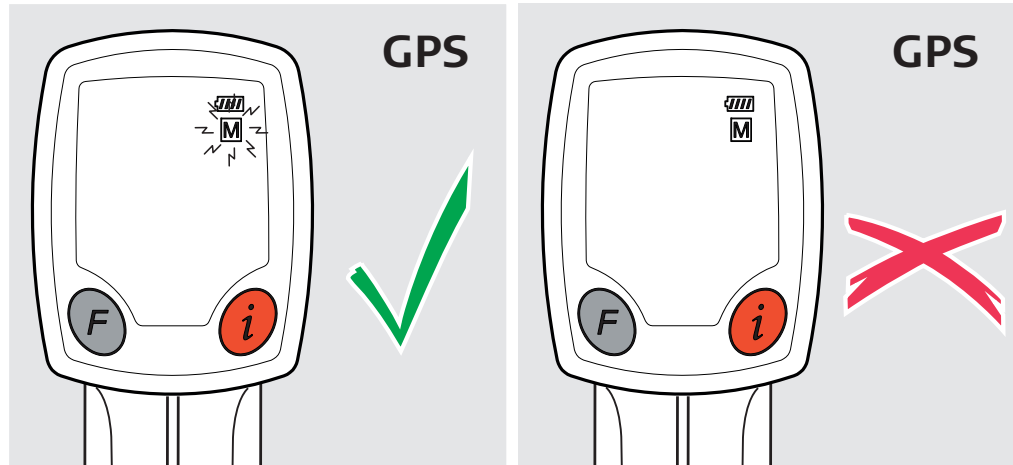



GPS Search Mode (i700, i750 & i750xf)

A GPS search mode is activated as part of the start up test allowing the internal GPS module time to search for a GPS position. GPS search mode is active following the start up test even if the locator is off, the search mode will stop when a GPS position is obtained or a 12 minute search period has elapsed.

GPS search mode does not affect the locator's performance and the locator can be used as normal throughout this search mode.



When retrieving log files from the i700, i750 & i750xf "P.C" must be selected from the "COM" setting as described in section 2.3 Locator Setup and Information.

COM Setting Options

PC: Enables Bluetooth communication to Logicat Software

BT1: Enables Bluetooth option 1 (refer to section 2.6)

BT2: Enables Bluetooth option 2 (refer to section 2.6)

GPS: Switches GPS on following use with BT1 or BT2 settings



BT1 and BT2 connections will be maintained for a three hour period when selected, during this period the GPS will be off. The GPS will automatically activate after the three hour period has elapsed or GPS is selected from the COM Setting.

3 How to Use the Transmitter

3.1 General information

Tracing signal

The Transmitter applies an electrical current (signal) onto a buried metallic service, which enables the service to be traced and identified by the Locator operating in the same mode.

Operating mode

There are three operating modes for onsite flexibility:

- 33 kHz for general usage
- 8 kHz for medium range tracing and reduced coupling on to other services.
- Combined 8 kHz and 33 kHz (Connection mode only) is useful in congested areas when either 8 kHz or 33 kHz may provide a better result. The best results can be simply achieved by switching modes on the Locator.

Plus two additional operating modes on the xf transmitters (connection mode only):

- 640 Hz for long distance tracing and reduced coupling on to other services. Generally used in Countries where the mains electrical frequency is 50 Hz.
 - 512 Hz for long distance tracing and reduced coupling on to other services. Generally used in Countries where the mains electrical frequency is 60 Hz.
-

Description

Active tracing is a term frequently used when a Transmitter is used to apply a signal to a service enabling it to be traced. The use of a Transmitter will greatly improve the detection of services especially ones which may not have a signal on them.

The signal from the Transmitter can be applied to services in two ways:

- **Induction mode** (8 kHz or 33 kHz):
Induction is a quick and simple way to apply a signal to a service without the need to make any physical connection to it. The Transmitter uses an internal aerial to transmit the signal, therefore it should be noted that the signal will apply itself to additional services within close proximity to the Transmitter.
 - **Connection mode** (8 kHz, 33 kHz, combined 8 kHz and 33 kHz, additionally 512 Hz, 640 Hz on xf Transmitters):
This is the most efficient way of applying a signal to a service, and should be used whenever possible. The Transmitter's cable set or any of the available accessories are connected to the service which is to be traced or identified.
-

3.2

Transmitter Overview

Transmitter main parts

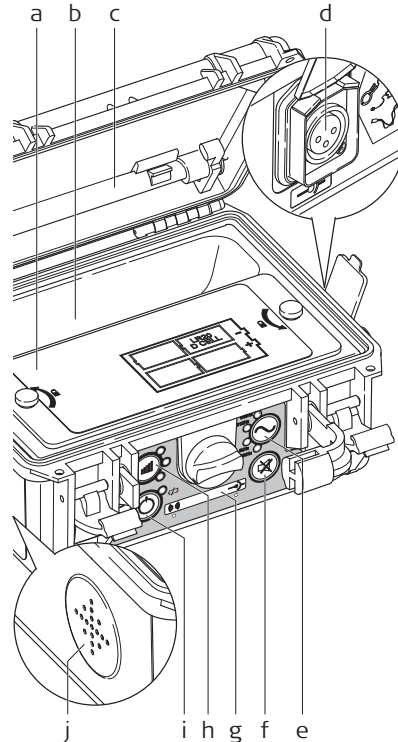

- a) Battery Cover**
- b) Accessory Compartment**
- c) Earth Pin**
- d) Connection Socket**
Used to connect accessories directly to metallic services. (Standard: crocodile clip cable set.)
- e) Frequency Control and Indicator**
Used to set the Transmitters frequency output. LED illuminates to indicate selection.
- f) Mute Control**
Used to silence the Transmitter.
- g) Mode Display**
Indicates which mode is selected; Induction or Connection
- h) Power Output Control and Indicator**
Press the control to set the Transmitters power output.
Level 1, minimum power output indicated by the bottom LED illuminated.
Level 4, maximum power output indicated by all LED's illuminated. Default setting Level two.
- i) On - Off control**
Press to switch the transmitter on and off.
- j) Speaker**

Changing the battery

The battery indicator flashes to indicate a poor battery condition.

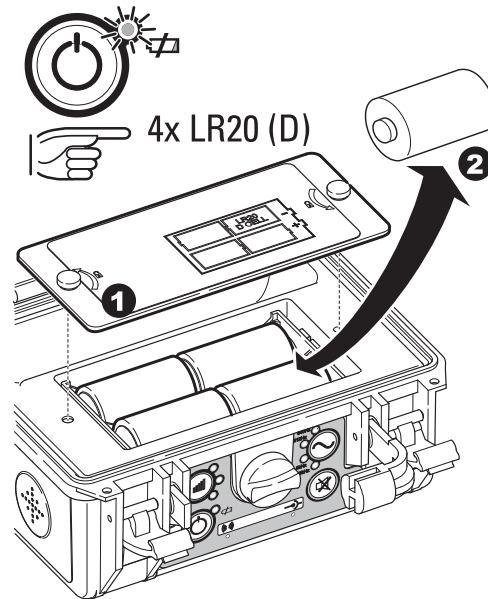

1. Unscrew the two fasteners and remove the cover.
2. Replace all batteries with four new LR20 (D) type alkaline batteries, or remove and recharge the battery pack if rechargeable batteries are fitted.

 **Warning**

Risk of electric shock when removing the Transmitter's battery pack.

Precautions:

Before removing the battery pack switch the transmitter off and remove any cable set or accessories from the connection socket.

 **Caution**

The Transmitter's battery pack may get hot after prolonged use.

Precautions:

Allow the battery pack to cool down before removing.

3.3

How to Locate a Service Using the Transmitter

Start up test

The following test sequence will take place every time the Transmitter is activated.

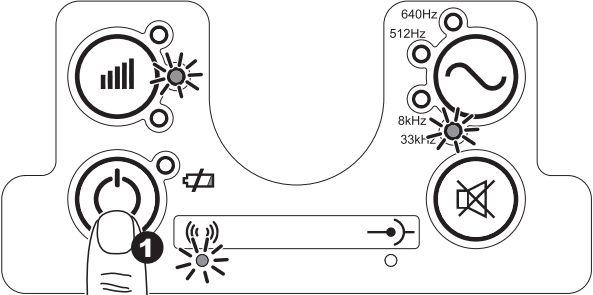
On test	Test pattern
	
Audio output	On throughout test sequence.
LEDs	LEDs are all lit throughout the test sequence.
Default mode selection	33 kHz and power output level two is automatically selected. Induction mode is selected unless the Transmitter's cable set or accessories are connected.

Using the Transmitter in Induction mode

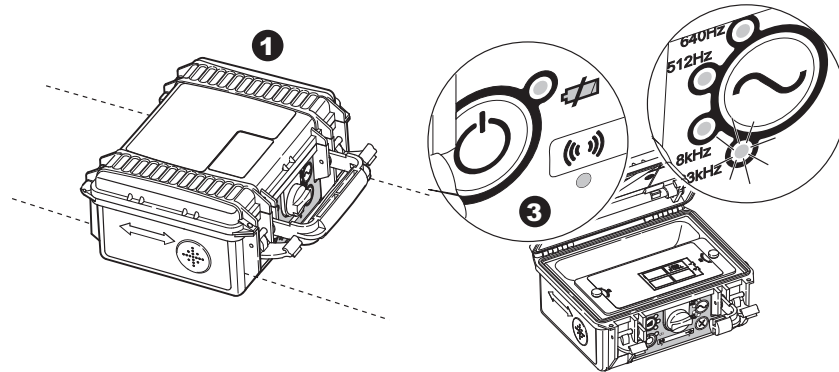

1. Switch the Transmitter on, observe the Induction mode LED is illuminated and the battery level is adequate. Change batteries when indicated.
2. Select the required power output level and frequency output.
3. Place the Transmitter over the service with the arrows running in line with the suspected direction of the service.
4. The tracing signal is induced directly onto the service from the internal aerial.
5. Trace the suspected path of the service using the Locator set to the same frequency. Refer to "2 How to Use the Locator" for more information.



- Work at least 10 m / 33 ft away from the Transmitter to avoid airborne signals. Reposition the Transmitter if required.
- Coupling efficiency is best at 33 kHz.
- The signal will couple to adjacent services dependent on depth and direction.
- Reducing the signal output can help to increase the battery life and the Transmitter is less likely to apply a signal to an adjacent service.

Using the Transmitter in Connection mode

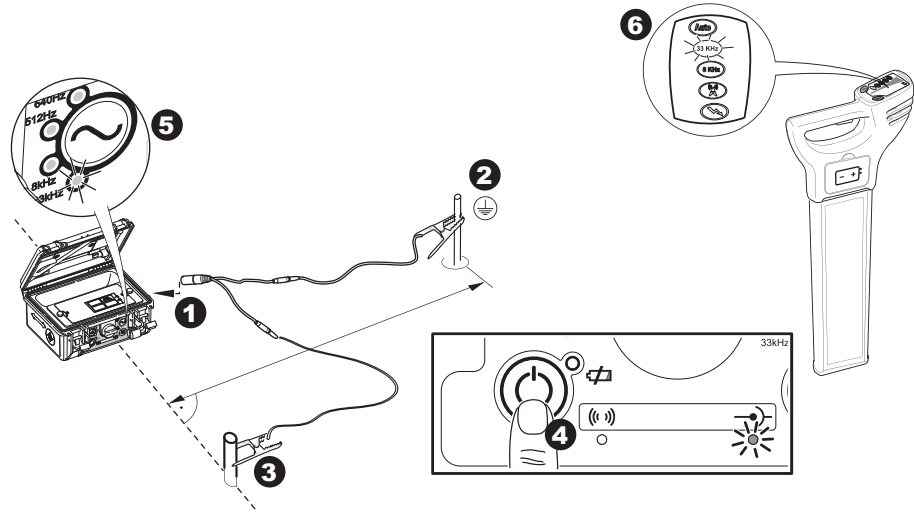

1. Plug the Transmitter's cable set into the connection socket.
2. Connect the black cable to the Earth Pin, ensuring that no services are below push the Earth Pin into the ground.
3. Connect the red cable to the service.
4. Switch the Transmitter on, observe the Connection mode LED is illuminated and the battery level is adequate. Change batteries when indicated.
5. Select the required power output level and frequency output. A good level of tracing signal is indicated when the power output LED & audible tone changes from pulsed to continuous.
6. Trace the signal using the Locator set to the same operating mode. Refer to "2 How to Use the Locator" for more information.

 **Danger**

Connecting the cable set to a live service can result in an electric shock.

Precautions:

The connection cable set should never be connected directly to a live service.

 **Warning**

The transmitter is capable of outputting potentially lethal voltages.

Precautions:

Care should be taken when handling exposed or non-insulated connections including; the connection cables sets, the Earth Pin and the connection to the service.

Notify others who may be working on or around the service.

 **Warning**

The transmitter is capable of outputting potentially lethal voltages.

Precautions:

Care should be taken when using the maximum power output level.



- Ensure there are no services below the ground when using the Earth Pin. Use the Locator in advance.
- The black cable can be connected to other metallic structures which go into the ground.
- In dry conditions it may be necessary to add water around the earth point to get a good connection.
- Examine connection points and remove contamination if a continuous audible output is not achieved.
- An extension cable is available to extend the red or black cable sets.

4

How to Use the Conductive Rod

4.1

General Information

Description

The Conductive Rod is a service tracer enabling small diameter non-conductive pipes or ducts to be traced. It can be used in Line mode or Sonde mode.

4.2

Conductive Rod Overview

Conductive Rod main parts

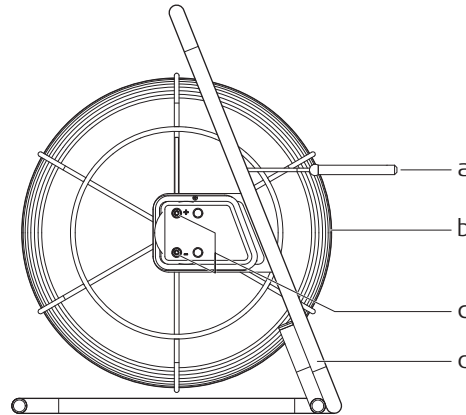

- a) **End of Coil: Sonde mode**
Used to accurately pinpoint the end point of the rod.
 - b) **Rod: Line mode**
Flexible, Glass Fibre sheathed, which incorporates copper wires to conduct the signal.
 - c) **Connection Terminals**
Used to connect to the Transmitter.
 - d) **Frame**
Houses the flexible rod. Can be used in both vertical (shown) and horizontal orientation.
-

4.3

How to Locate a Service Using the Conductive Rod

Using the Conductive Rod in Line mode

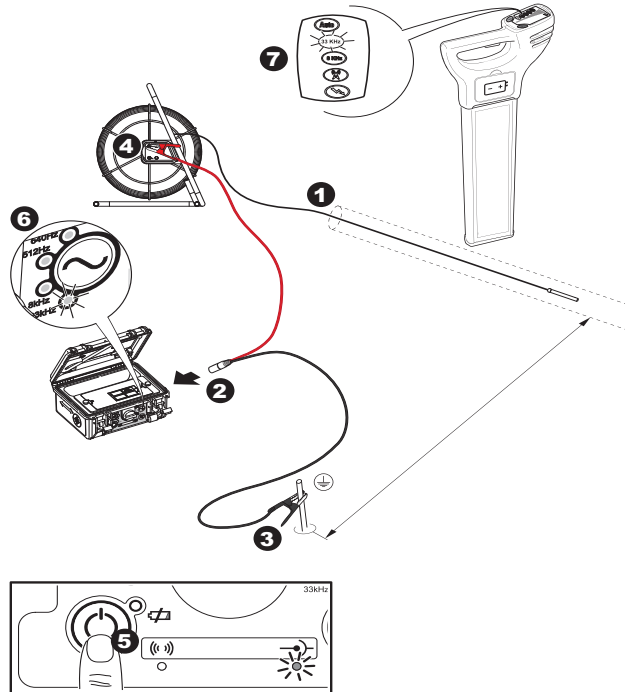

1. Insert the rod into the pipe, duct, conduit or drain until the desired length is in place.
2. Plug the Transmitter's cable set into the connection socket
3. Connect the black cable to the Earth Pin, ensuring that no services are below push the Earth Pin into the ground
4. Connect the red cable to the positive (+) terminal on the conductive rod.
5. Switch the Transmitter on, observe the Connection mode LED is illuminated and the battery level is adequate. Change batteries when indicated.
6. Select the required power output level and frequency output. A good level of tracing signal is indicated when the power output LED & audible tone changes from pulsed to continuous
7. Trace the length of the rod using the Locator set to the same frequency.



- Ensure there are no services below the ground when using the Earth Pin. Use the Locator in advance.
 - At least half the Conductive Rod needs to be uncoiled when in use.
-

Using the Conductive Rod in Sonde mode

1. Insert the rod into the pipe, duct, conduit or drain until the desired length is in place.
2. Plug the Transmitter's cable set into the connection socket. Connect the red cable to the positive (+) terminal on the conductive rod, connect the black cable to the negative (-) terminal.
3. Switch the Transmitter on and select the required power output level and frequency output. A good level of tracing signal is indicated when the power output LED & audible tone changes from pulsed to continuous. The signal applies itself along the length of the Conductive Rod.
4. Trace the length of the rod using the Locator set to the same frequency.



At least half the Conductive Rod needs to be uncoiled when in use.

5 How to Use the Signal Clamp

5.1 General Information

Description

The Signal Clamp provides a safe technique of applying a signal to services such as telecom cables, etc. It is connected to the Transmitter and then clipped around the service. Supply is not interrupted by the applied signal.

5.2 Signal Clamp Overview

Signal Clamp main parts

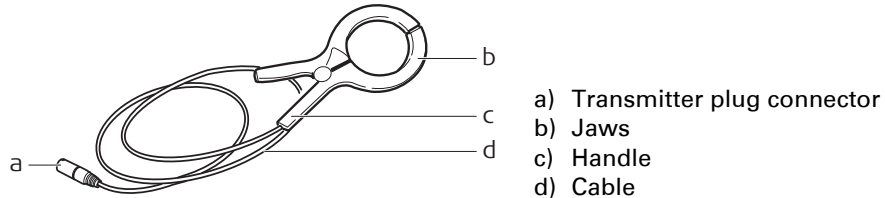

5.3

How to Locate a Service Using the Signal Clamp

Using the Signal Clamp

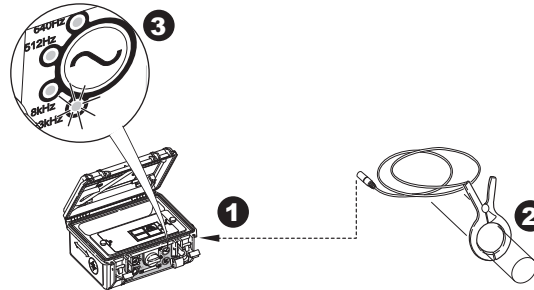

1. Connect the Signal Clamp to the Transmitter.
2. Open the jaws of the Signal Clamp and place around the service to be traced.
3. Switch the Transmitter on and select the required power output level, set the frequency output to correspond with the clamp. A good level of tracing signal is indicated when the audible tone and power output LED are continuous.
4. Trace the length of the service using the Locator set to the same frequency.



- Ensure the clamp jaws are fully engaged.
- Ensure the Transmitter's frequency output is comparable to that of the Signal Clamp. Check the signal clamps type plate for the frequency rating.

 **Danger**

A hazardous signal may be present on the connection plug of the Signal Clamp when clipped over a live service.

Precautions:

The clamp should be connected to the Transmitter before clamping around a live service.

 **Danger**

A hazardous signal may be present on the service causing personal harm.

Precautions:

Do not use on electrical services which have impaired, or no insulation. If in doubt do not use.

6 How to Use the Property Connection Set

6.1 General Information

Description

The Property Connection Set provides a safe technique of applying a traceable signal to live electricity cables. It is connected to the service via a mains plug outlet and provides a traceable signal. Supply is not interrupted by the applied signal and the risk of serious injury is greatly reduced.

6.2 Property Connection Set Overview

Property Connection Set main parts

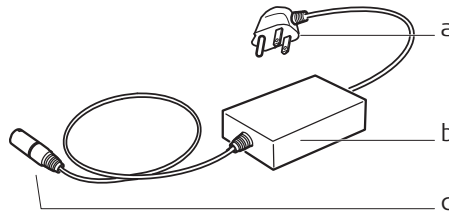

- a) Mains plug connector
- b) In line isolator
- c) Transmitter plug connector

6.3

How to Locate a Service Using the Property Connection Set

Using the Property Connection Set

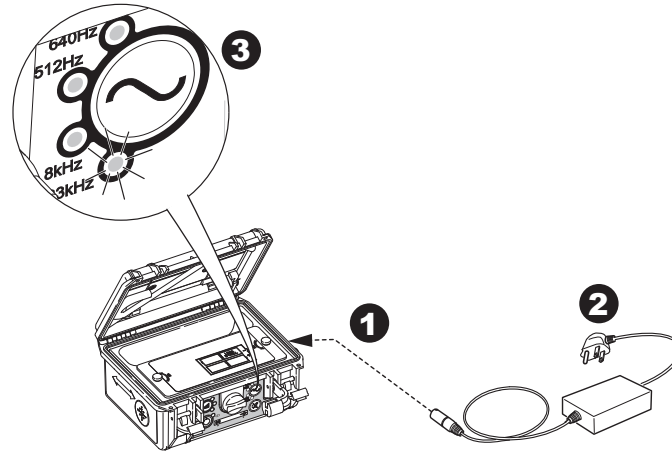

1. Connect the Property Connection Set to the Transmitter.
2. Connect the Property Connection Set to a live mains outlet. Ensure the switch on the mains is on.
3. Switch the Transmitter on and select the required power output level, set the frequency output to correspond with the Property Connection Set. A good level of tracing signal is indicated when the audible tone and power output LED are continuous.
4. Trace the length of the service using the Locator set to the same frequency.



- The mains supply must be live and switched on for correct operation.
- Ensure the Transmitter's frequency output is comparable to that of the Property Connection Set.
- Check the Property Connection Set type plate for the frequency rating.

 **Danger**

A hazardous signal may be present on the connection plug of the Property Connection Set when connected to the mains supply.

Precautions:

The Property Connection Set should be connected to the Transmitter before connecting to the mains supply.

 **Danger**

When using a Property Connection Set a hazardous signal may be present on the service or mains outlet causing personal harm.

Precautions:

Do not use on electrical services which have impaired, or no insulation. If in doubt do not use. Replace damaged Property Connection Set cable assembly before use.

7 How to Use the Sonde

7.1 General Information

Description

The Sonde is a dual frequency signal transmitter used to trace drains, sewers and other non conductive services. It can be attached to a range of equipment including drain rods, boring tools and inspection cameras. It is powered by a 1.5 V LR6 (AA) battery, so unlike other accessories this does not require a connection to the transmitter.

The signal pattern transmitted from the Sonde is different to that which is radiated from a service; transmitting a peak signal over its main body, with a ghost signal at the front and back. This requires the Sonde to be traced with its own unique method.

The i-Series Locators feature a numeric signal strength indicator (user setting **SSI** set to ON) which will greatly improve the locating process.



The numeric signal strength indicator is shown in the display readout on the Locator.

7.2 Sonde Overview

Sonde main parts

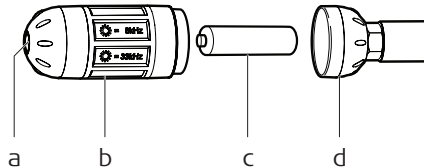

- a) LED
- b) Sonde body
- c) LR6 (AA) battery
- d) End cap and M10 connection point



The thread on the Sonde is a male M10, and comes with adaptors to both British and European drain rods.

Changing the frequency output

Changing to 33 kHz mode:

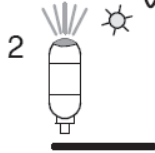
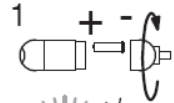

1. Unscrew and remove end cap.
Insert battery, positive end first.
Refit end cap securely.
2. Hold Sonde upright.
Confirm green LED is continuous.
3. Wait approximately 10 seconds for the green LED to start flashing.
4. With the green LED flashing, the Sonde is ready for use at 33 kHz.

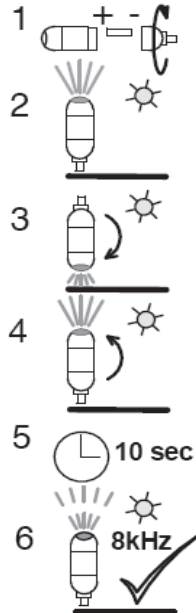
Changing to 8 kHz mode:

1. Unscrew and remove end cap.
Insert battery, positive end first.
Refit end cap securely.
2. Hold Sonde upright.
Confirm green light is continuous.
3. Rotate Sonde so the LED points down and wait approximately 1 second.
4. Rotate Sonde upright.
Confirm the amber coloured LED is continuous.
If LED remains green repeat from step 1.
5. Wait approximately 10 seconds for the amber LED to start flashing.
6. With the amber LED flashing, the Sonde is ready for use at 8 kHz.



Once the function of the Sonde has been checked with a Locator set to the same operating mode it can be attached to drain rods or other means of guiding it into the service being traced.

7.3

How to Locate a Service Using the Sonde

Locating the Sonde

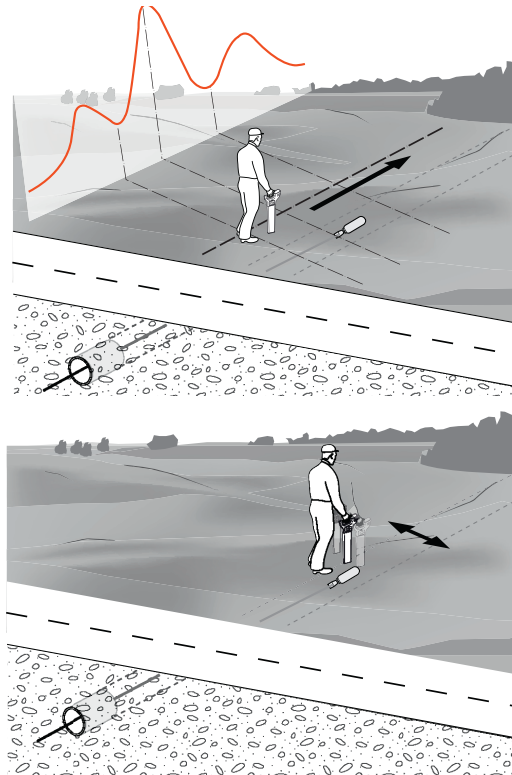

1. Walk in line with the suspected direction of travel observing the display. The signal strength indicator will rise and fall as you pass over the ghost signal at the back of the Sonde, the peak signal directly over the Sonde and the ghost signal at the front. The numeric signal strength indicator will display its highest value when detecting the peak signal.
2. Retrace your steps and position the locator directly over the peak signal. Move the locator left and right until the highest numeric reading is obtained. This reading will indicate the Sonde's precise location.

3. Depth indication (refer to Sonde Depth in How to Use the Locator section)

Depth indication can be used with a suitable depth locator. The locator must be positioned directly over the Sonde and in line with it (rotate the locator on its axis to find the highest reading). Press and hold the i Button for 2 seconds. The depth of the Sonde will be displayed in the depth readout window and the Sonde mode icon will be visible beneath the display.



- For ease and convenience mark the ground every 3 to 4 metres.
- For ease of use practice the process above ground

Tracing a "walk through" sewer

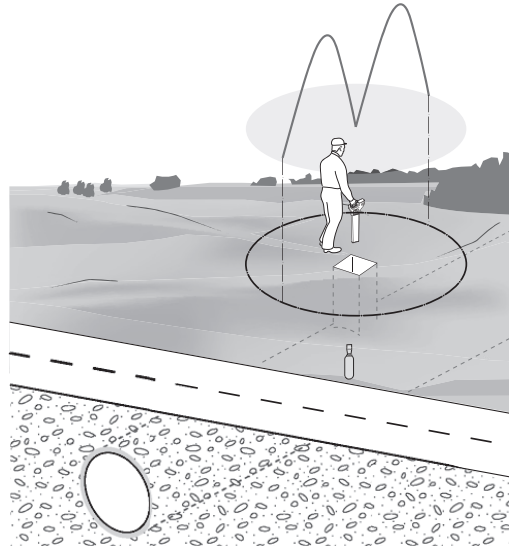

If a "walk through" sewer is being traced, another method is to place the Sonde vertically, for example to pinpoint a buried manhole. The Locator will pick up a pool of signal with a null point at the centre. This is an accurate method, but it is essential to ensure the Sonde is vertical.

8

Care and Transport

8.1

Transport

Transport in the field

When transporting the equipment in the field, always make sure that you carry the product in its original transport container.

Transport in a road vehicle

Never carry the product loose in a road vehicle, as it can be affected by shock and vibration. Always carry the product in its transport container and secure it.

Shipping

When transporting the product by rail, air or sea, always use the complete original Cable Detection packaging, transport container and cardboard box, or its equivalent, to protect against shock and vibration.

Shipping, transport of batteries

When transporting or shipping batteries, the person in charge of the product must ensure that the applicable national and international rules and regulations are observed. Before transportation or shipping, contact your local passenger or freight transport company.

8.2

Storage

Product

Respect the temperature limits when storing the equipment, particularly in summer if the equipment is inside a vehicle. Refer to "10 Technical Data" for information about temperature limits.

If the equipment is to be stored for a long time, remove the alkaline batteries from the product in order to avoid the danger of leakage.

8.3**Cleaning and Drying**

Damp products

Dry the product, the transport container, the foam inserts and the accessories at a temperature not greater than 40°C / 104°F and clean them. Do not repack until everything is completely dry.

Cables and plugs

Keep plugs clean and dry. Blow away any dirt lodged in the plugs of the connecting cables.

9

Safety Directions

9.1

General Introduction

Description

The following directions should enable the person responsible for the product, and the person who actually uses the equipment, to anticipate and avoid operational hazards.

The person responsible for the product must ensure that all users understand these directions and adhere to them.

9.2

Intended Use

Permitted use

The products are intended to be used for the following applications:

- Detection and localization of underground services: cables and metallic pipes.
 - Locator: Detection and localization of a Sonde Transmitter.
 - Locator: Detection and localization of Conductive Rod accessory.
 - Locator i550, i650, **i750**, i550xf, i650xf, i750xf: Estimation of the depth of an underground service, a Sonde or Conductive Rod.
 - Locator with Bluetooth: Data communication with external appliances.
-

Adverse use

- Use of the product without instruction.
- Use outside of the intended use and limits.
- Disabling safety systems.
- Removal of hazard notices.
- Opening the product using tools, for example screwdriver, unless this is specifically permitted for certain functions.
- Modification or conversion of the product.
- Use after misappropriation.

- Use of products with obviously recognizable damages or defects.
- Use with accessories from other manufacturers without the prior explicit approval of Cable Detection.
- Inadequate safeguards at the surveying site, for example when measuring on roads.

 **Warning**

Adverse use can lead to injury, malfunction and damage. It is the task of the person responsible for the equipment to inform the user about hazards and how to counteract them. The product is not to be operated until the user has been instructed on how to work with it.

9.3**Limits of Use****Environment**

Suitable for use in an atmosphere appropriate for permanent human habitation: not suitable for use in aggressive or explosive environments.

 **Danger**

Local safety authorities and safety experts must be contacted before working in hazardous areas, or in close proximity to electrical installations or similar situations by the person in charge of the product.

9.4**Responsibilities****Manufacturer of the product**

Cable Detection Ltd, Staffordshire, UK, hereinafter referred to as Cable Detection, is responsible for supplying the product, including the user manual and original accessories, in a completely safe condition.

Manufacturers of non Cable Detection accessories

The manufacturers of non Cable Detection accessories for the product are responsible for developing, implementing and communicating safety concepts for their products, and are also responsible for the effectiveness of those safety concepts in combination with the Cable Detection product.

Person in charge of the product

The person in charge of the product has the following duties:

- To understand the safety instructions on the product and the instructions in the user manual.
- To ensure that it is used in accordance with the instructions.
- To be familiar with local regulations relating to safety and accident prevention.
- To inform Cable Detection immediately if the product and the application becomes unsafe.

Warning

The person responsible for the product must ensure that it is used in accordance with the instructions. This person is also accountable for the training and the deployment of personnel who use the product and for the safety of the equipment in use.

9.5

Hazards of Use

Warning

The absence of instruction, or the inadequate imparting of instruction, can lead to incorrect or adverse use, and can give rise to accidents with far-reaching human, material, financial and environmental consequences.

Precautions:





All users must follow the safety directions given by the manufacturer and the directions of the person responsible for the product.

Caution

Watch out for erroneous measurement results if the product has been dropped or has been misused, modified, stored for long periods or transported.

Precautions:

Periodically carry out test measurements and perform tests indicated in the user manual, particularly after the product has been subjected to abnormal use and before and after important measurements.

-
-  **Danger**
- Because of the risk of electrocution, it is very dangerous to use the product in the vicinity of electrical installations such as power cables or electrical railways.
- Precautions:**
Keep at a safe distance from electrical installations. If it is essential to work in this environment, first contact the safety authorities responsible for the electrical installations and follow their instructions.
-
-  **Warning**
- During dynamic applications, for example stakeout procedures there is a danger of accidents occurring if the user does not pay attention to the environmental conditions around, for example obstacles, excavations or traffic.
- Precautions:**
The person responsible for the product must make all users fully aware of the existing dangers.
-
-  **Caution**
- The absence of a positive indication does not guarantee the non-existence of a service. Services without a detectable signal may be present.
- The Locators can only locate non-metallic services such as plastic pipes, typically used by the water and gas utilities, with the use of appropriate accessories.
- Precautions:**
Always excavate with care.
-
-  **Warning**
- Only with a Locator with depth:**
The depth reading might not reflect the real depth if your Locator picks up the signal induced into the service by the Transmitter. This signal is radiated from the centre of the service.
- This is even more important when the signal is produced by a Sonde, lying in a large diameter conduit!
- Precautions:**
Always compensate depth reading for service size.
-

 **Danger**

The Locator may fail to detect electrical services in Power mode if an incorrect power setting is used.

Precautions:

Before use, verify the Locator is setup to be compatible with mains frequency supply in your country. Options are 50 or 60 Hz. Refer to "Appendix B World Frequency Zones" (User Manual) for more information.

Contact your agency or Cable Detection authorised service workshop if your unit is incorrectly configured for your region.

 **Danger**

Only with Transmitter:

A hazardous signal may be present on the connection plug of the Signal Clamp when clipped over a live service.

Precautions:

The clamp should be connected to the Transmitter before clamping around a live service.

 **Danger**

Connecting the Transmitter's cable set to a live service can result in receiving an electric shock.

Precautions:





The Transmitter's cable set should never be connected directly to an electrical live service.

 **Danger**

When using a signal clamp, a hazardous signal may be present on the service causing personal harm.

Precautions:

Do not use on electrical services which have impaired, or no insulation. If in doubt do not use.

-
-  **Danger**
- When using a Property Connection Set a hazardous signal may be present on the service or mains outlet causing personal harm.
- Precautions:**
Do not use on electrical services which have impaired, or no insulation. If in doubt do not use. Replace damaged Property Connection Set cable assembly before use.
-
-  **Warning**
- Inadequate securing of the surveying site can lead to dangerous situations, for example in traffic, on building sites, and at industrial installations.
- Precautions:**
Always ensure that the survey site is adequately secured. Adhere to the regulations governing safety and accident prevention and road traffic.
-
-  **Warning**
- The transmitter is capable of outputting potentially lethal voltages.
- Precautions:**
Care should be taken when handling exposed or non-insulated connections including; the connection cables sets, the earth pin and the connection to the service. Notify others who may be working on or around the service.
-
-  **Warning**
- The transmitter is capable of outputting potentially lethal voltages.
- Precautions:**
Care should be taken when using the maximum power output level.
-

 **Warning**

Risk of electric shock when removing the Transmitter's battery pack.

Precautions:

Before removing the battery pack switch the transmitter off and remove any cable set or accessories from the connection socket.

 **Caution**

The Transmitter's battery pack may get hot after prolonged use.

Precautions:

Allow the battery pack to cool down before removing.

 **Warning**

If the product is improperly disposed of, the following can happen:





- If polymer parts are burnt, poisonous gases are produced which may impair health.
- If batteries are damaged or are heated strongly, they can explode and cause poisoning, burning, corrosion or environmental contamination.
- By disposing of the product irresponsibly you may enable unauthorised persons to use it in contravention of the regulations, exposing themselves and third parties to the risk of severe injury and rendering the environment liable to contamination.
- Improper disposal of silicone oil may cause environmental contamination.

Precautions:



The product must not be disposed with household waste. Dispose of the product appropriately in accordance with the national regulations in force in your country. Always prevent access to the product by unauthorised personnel.

Product specific treatment and waste management information can be downloaded from the Cable Detection home page at <http://www.cabledetection.co.uk/treatment> or received from your Cable Detection dealer.

 Caution	<p>During the transport, shipping or disposal of batteries it is possible for inappropriate mechanical influences to constitute a fire hazard.</p> <p>Precautions: Before shipping the product or disposing of it, discharge the batteries by running the product until they are flat. When transporting or shipping batteries, the person in charge of the product must ensure that the applicable national and international rules and regulations are observed. Before transportation or shipping contact your local passenger or freight transport company.</p>
 Warning	<p>High mechanical stress, high ambient temperatures or immersion into fluids can cause leakage, fire or explosions of the batteries.</p> <p>Precautions: Protect the batteries from mechanical influences and high ambient temperatures. Do not drop or immerse batteries into fluids.</p>
 Warning	<p>If battery terminals come in contact with jewellery, keys, metallised paper or other metals, short circuited battery terminals can overheat and cause injury or fire, for example by storing or transporting in pockets.</p> <p>Precautions: Make sure that the battery terminals do not come into contact with metallic objects.</p>
 Warning	<p>Only Cable Detection authorised service workshops are entitled to repair these products.</p>

9.6

Electromagnetic Compatibility EMC

Description

The term Electromagnetic Compatibility is taken to mean the capability of the product to function smoothly in an environment where electromagnetic radiation and electrostatic discharges are present, and without causing electromagnetic disturbances to other equipment.

 **Warning**

Electromagnetic radiation can cause disturbances in other equipment.

Although the product meets the strict regulations and standards which are in force in this respect, Cable Detection cannot completely exclude the possibility that other equipment may be disturbed.

 **Caution**

There is a risk that disturbances may be caused in other equipment if the product is used in conjunction with accessories from other manufacturers, for example field computers, personal computers, two-way radios, non-standard cables or external batteries.

Precautions:

Use only the equipment and accessories recommended by Cable Detection. When combined with the product, they meet the strict requirements stipulated by the guidelines and standards. When using computers and two-way radios, pay attention to the information about electromagnetic compatibility provided by the manufacturer.

 **Caution**

Disturbances caused by electromagnetic radiation can result in erroneous measurements. Although the product meets the strict regulations and standards which are in force in this respect, Cable Detection cannot completely exclude the possibility that the product may be disturbed by very intense electromagnetic radiation, for example, near radio Transmitters, two-way radios or diesel generators.

Precautions:

Check the plausibility of results obtained under these conditions.

 **Warning**

If the product is operated with connecting cables attached at only one of their two ends, for example external supply cables, interface cables, the permitted level of electromagnetic radiation may be exceeded and the correct functioning of other products may be impaired.

Precautions:

While the product is in use, connecting cables, for example product to external battery, product to computer, must be connected at both ends.

 **Warning**

Electromagnetic fields can cause disturbances in other equipment, in installations, in medical devices, for example pacemakers or hearing aids and in aircraft. It can also affect humans and animals.

Precautions:

Although the product meets in combination with radio or digital cellular phone devices recommended by Cable Detection the strict regulations and standards which are in force in this respect, Cable Detection cannot completely exclude the possibility that other equipment may be disturbed or that humans or animals may be affected.

- Do not operate the product with radio or digital cellular phone devices in the vicinity of filling stations or chemical installations, or in other areas where an explosion hazard exists.
 - Do not operate the product with radio or digital cellular phone devices near to medical equipment.
 - Do not operate the product with radio or digital cellular phone devices in aircraft.
 - Do not operate the product with radio or digital cellular phone devices for long periods with it immediately next to your body.
-

9.7

FCC Statement, Applicable in U.S.

Warning

This equipment has been tested and found to comply with the limits for a Class B digital device, pursuant to part 15 of the FCC rules.

These limits are designed to provide reasonable protection against harmful interference in a residential installation.

This equipment generates, uses and can radiate radio frequency energy and, if not installed and used in accordance with the instructions, may cause harmful interference to radio communications. However, there is no guarantee that interference will not occur in a particular installation.

If this equipment does cause harmful interference to radio or television reception, which can be determined by turning the equipment off and on, the user is encouraged to try to correct the interference by one or more of the following measures:

- Reorient or relocate the receiving antenna.
- Increase the separation between the equipment and the receiver.
- Connect the equipment into an outlet on a circuit different from that to which the receiver is connected.
- Consult the dealer or an experienced radio/TV technician for help.

Warning



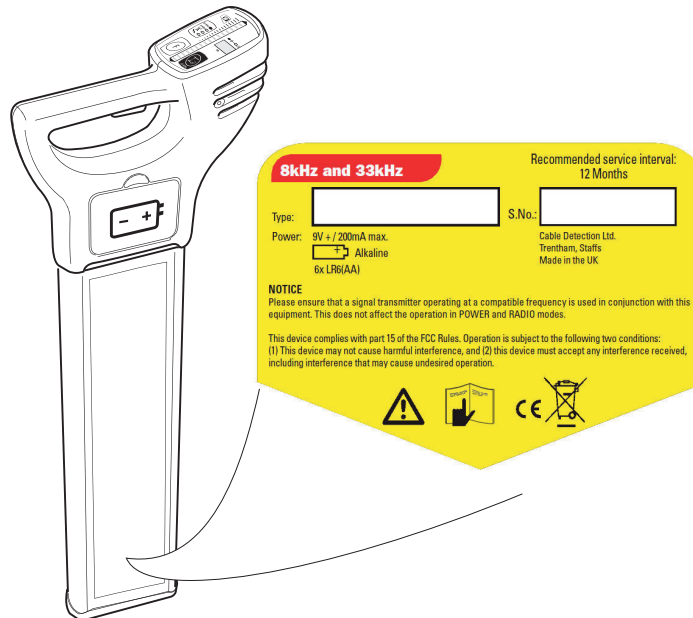

Changes or modifications not expressly approved by Cable Detection for compliance could void the user's authority to operate the equipment.

Labelling Locator



Labelling Transmitter

Power 
4xLR20 (D) Alkaline
6V = / 2A Max.
NiMH 4.8V = / 9000mA.

    

Cable Detection Ltd.
Stoke-On-Trent
Staffordshire.

Type	Art.No.	Ser.No.

This device complies with part 15 of the FCC Rules. Operation is subject to the following two conditions: (1) This device may not cause harmful interference, and (2) this device must accept any interference received, including interference that may cause undesired operation.

Made in the UK

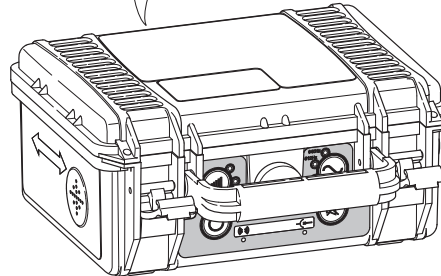

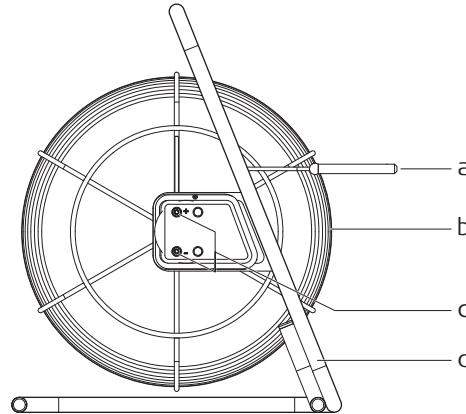
Conductive Rod

- a) **End of Coil: Sonde mode**
Used to accurately pinpoint the end point of the rod.
 - b) **Rod: Line mode**
Flexible, Glass Fibre sheathed, which incorporates copper wires to conduct the signal.
 - c) **Connection Terminals**
Used to connect to the Transmitter.
 - d) **Frame**
Houses the flexible rod. Can be used in both vertical (shown) and horizontal orientation.
-

Signal Clamp

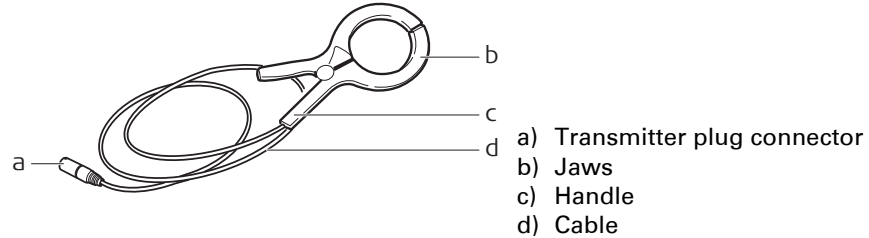

Property Connection Set

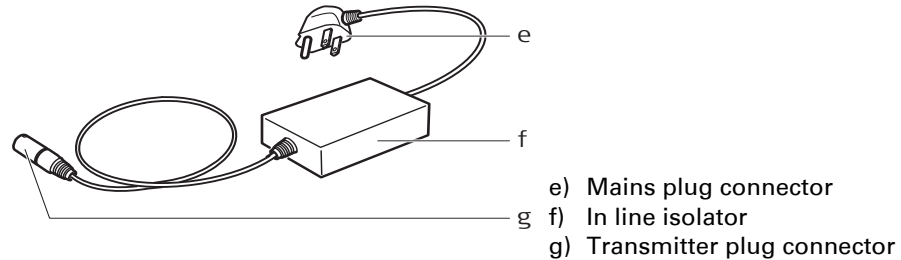

10**Technical Data****10.1****Locator i-Series Technical Data****Typical detection range**

Mode	Distance along conductor
Power mode	length of conductor
Radio mode	length of conductor
Conductive Rod mode	length of unwound rod

Operating depth range

Mode	Range
Power mode	to 3 m / 10 ft
Radio mode	to 2 m / 7 ft
Transmitter mode	Dependent on Transmitter and service type

Typical depth accuracy

EZiCAT i550, i650, i750	EZiCAT i550xf, i650xf, i750xf
10% of depth in line or Sonde	10% of depth in line or Sonde
0.3 to 3.0 m (1 to 10 ft) Line Mode 0.3 to 3.0 m (1 to 10 ft) Sonde Mode	0.3 to 3.0 m (1 to 10 ft) Line Mode 0.3 to 9.99 m (1 to 32 ft 9 inches) Sonde Mode

Operating frequencies

Mode	Frequency
Power mode	50 Hz or 60 Hz
Radio mode	15 kHz to 60 kHz
8 kHz mode	8.192 (8) kHz
33 kHz mode	32.768 (33) kHz
Auto mode	Power mode and Radio mode
512 Hz (xf models)	512 (512) Hz
640 Hz (xf models)	640 (640) Hz

Bluetooth (when fitted)

Class 2, nominal range 30 m

Memory capacity

i600, i650, i600xf, i650xf: 32 Mb
i700, i750, i750xf: 64 Mb

**GPS Sensor
(i700, i750, i750xf)**

- Chipset: MediaTek MT3329, WAAS/EGNOS capable ⁽¹⁾
- Type: L1 frequency, C/A code (SPS)
- Channels: 22 tracking + 66 search channels
- Accuracy⁽²⁾: Position 1.8m (CEP95), Velocity 0.1m/s, Time +/-50ns (RMS)
- Start time: Cold 12 min max (34s typical), Warm 34s typical, Hot 1s typical

⁽¹⁾ WAAS available in North America only, EGNOS available in Europe only.

⁽²⁾ Accuracy is dependent upon various factors including atmospheric conditions, multipath, obstructions, signal geometry and number of tracked satellites.

Display panel

- 48 segment bar graph
 - 5 mode indicators (Standard), 7 mode indicators (xf models)
 - Battery status indicator
 - Line depth indicator
 - Sonde depth indicator
 - Bluetooth indicator (where fitted)
 - Integrated backlight
 - Annual service indicator
 - 3 alpha numeric dot matrix displays 5x7
 - Signal Strength Indicator
 - mA (milliamperes)
 - Memory & GPS
-

Keypad

2 membrane push buttons

Speakers

- **Dual speakers:**

Audio volumes: 85 dBA @ 30 cm

Tone:

Power, Radio and Auto mode:

Continuous tone (different pitch for each mode).

8 kHz and 33 kHz mode:

Pulsed tone (different pitch for each mode).

512 Hz and 640 Hz mode:

Pulsed tone (different pitch for each mode).

All tones are different.

- **Pneumatic headphone sockets are integrated**
-

Internal battery

Type: 6 x LR6 (AA) alkaline
Typical operating time: 40 hrs intermittent use at 20°C / 68°F; in 8 kHz mode or 33 kHz mode

Instrument dimensions

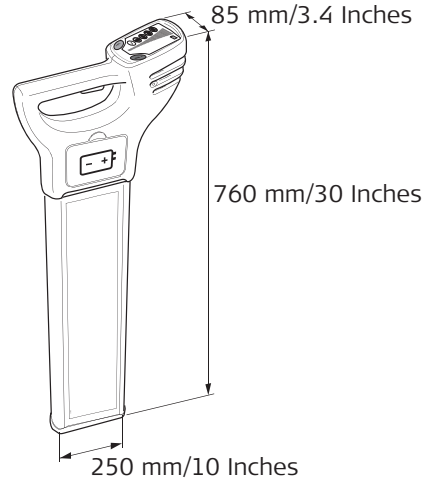

Weight

Instrument: 2.7 kg / 6 lbs
(including batteries)

Environmental specifications

Type		Description
Temperature	Operating	-20°C to +50°C -4°F to +122°F
	Storage	-40°C to +70°C -40°F to +158°F
Protection	against Water, Dust and Sand	IP54 (IEC 60529) Dust-protected
Humidity		95% RH non condensing The effects of condensation are to be effectively counteracted by periodically drying out the product.

Conformity to national regulations

- FCC Part 15 (applicable in US)
- Hereby, Cable Detection Ltd, declares that the EZiCAT i500/i550/i600/i650/i700/i750/i500xf/i550xf/i600xf/i650xf/i700xf/i750xf is in compliance with the essential requirements and other relevant provisions of Directive 1999/5/EC. The declaration of conformity may be consulted at <http://www.cabledetection.co.uk/ce>.



Class 1 equipment according European Directive 1999/5/EC (R&TTE) can be placed on the market and be put into service without restrictions in any EEA member state.

- The conformity for countries with other national regulations not covered by the FCC part 15 or European directive 1999/5/EC has to be approved prior to use and operation.

Frequency band

50 Hz to 60 kHz

Output power

Receive only

10.2

Transmitter Technical Data (1 Watt models)

Typical detection range

Mode	Output
Induction mode	Up to 1 W max.
Connection mode t100 & t100xf	Up to 1 W max. when connected to a buried service with an impedance of 100 Ω .
Connection mode t300 & t300xf	Up to 3 W max. when connected to a buried service with an impedance of 100 Ω .

Operating transmission frequencies

- 8.192 (8) kHz or
- 32.768 (33) kHz
- 512 (512) Hz (xf models)
- 640 (640) Hz (xf models)

Display panel

- 2 LED Mode Indicators
- 2 LED Frequency Indicators (Standard)
- 4 LED Frequency Indicators (xf models).
- LED Battery Status Indicator
- 3 LED Power Output Indicators

Keypad

4 membrane push buttons

Integral Speakers

Audio Volumes:	85 dBA @ 30 cm
Tone:	8 kHz mode: Low pitched tone 33 kHz mode: Higher pitched tone 512 Hz mode (xf models): Low pitched tone 640 Hz mode (xf models): Low pitched tone Induction mode: Pulsed tone Connection mode: Pulsed tone when poor or no current output, continuous tone when good connection

Internal battery

Type:	4 x D alkaline (IEC LR20), supplied
Typical operating time t100 & t100xf:	30 hrs intermittent use at 20 °C / 68 °F
Typical operating time t300 & t300xf:	15 hrs intermittent use at 20 °C / 68 °F

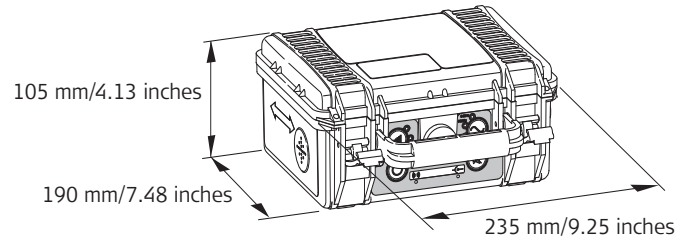
Instrument dimensions**Weight**

Instrument: (including batteries)	2.4 kg / 5.3 lbs
--------------------------------------	------------------

Environmental specifications

Type		Description
Temperature	Operating	-20°C to +50°C -4°F to +122°F
	Storage	-40°C to +70°C -40°F to +158°F
Protection against Water, Dust and Sand	With cover open	IP54 (IEC 60529) Dust-protected
	With cover closed and secured	IP65 (IEC 60529) Dust tight, Low power water jets.
Humidity		95% RH non condensing The effects of condensation are to be effectively counteracted by periodically drying out the product.

Conformity to national regulations

- FCC Part 15 (applicable in US)
- Hereby, Cable Detection Ltd, declares that the EZiTEX t100/t100xf/t300/t300xf is in compliance with the essential requirements and other relevant provisions of Directive 1999/5/EC. The declaration of conformity may be consulted at <http://www.cable-detection.co.uk/ce>.



Class 1 equipment according European Directive 1999/5/EC (R&TTE) can be placed on the market and be put into service without restrictions in any EEA member state.

- The conformity for countries with other national regulations not covered by the FCC part 15 or European directive 1999/5/EC has to be approved prior to use and operation.

10.3

Conductive Rod Technical Data

Typical detection range Both modes, Line and Sonde: Typical 3.0 m / 10 ft

Tracing distance 30 m/99 ft; 50 m/165 ft; 80 m/263 ft (maximum).
Reel length dependant

Operating transmission frequencies Dependent on Transmitter

Instrument dimensions

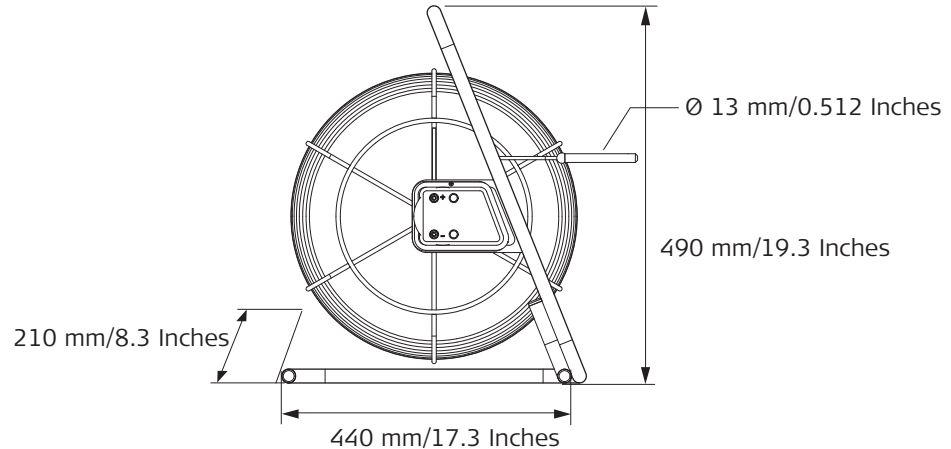

Weight

Instrument: 7.3 kg / 16.1 lbs

Environmental specifications

Type		Description
Temperature	Operating	-20°C to +50°C -4°F to +122°F
	Storage	-40°C to +70°C -40°F to +158°F
Protection against Water, Dust and Sand	Frame	IP54 (IEC 60529) Dust-protected
	Rod	Fully submersible
Humidity		95% RH non condensing The effects of condensation are to be effectively counteracted by periodically drying out the product.

Conformity to national regulations

- Hereby, Cable Detection Ltd, declares that the Conductive Rod is in compliance with the essential requirements and other relevant provisions of Directive 1999/5/EC. The declaration of conformity may be consulted at <http://www.cabledetection.co.uk/ce>.
-  Class 1 equipment according European Directive 1999/5/EC (R&TTE) can be placed on the market and be put into service without restrictions in any EEA member state.
- The conformity for countries with other national regulations not covered by the FCC part 15 or European directive 1999/5/EC has to be approved prior to use and operation.

10.4**Sonde Technical Data****Operating transmission frequencies**

- 8.192 (8) kHz or
- 32.768 (33) kHz

Internal battery

Type: 1 x LR6 (AA) alkaline
Typical operating time: 40 hrs intermittent use at 20°C / 68°F; in 8 kHz mode or 33 kHz mode

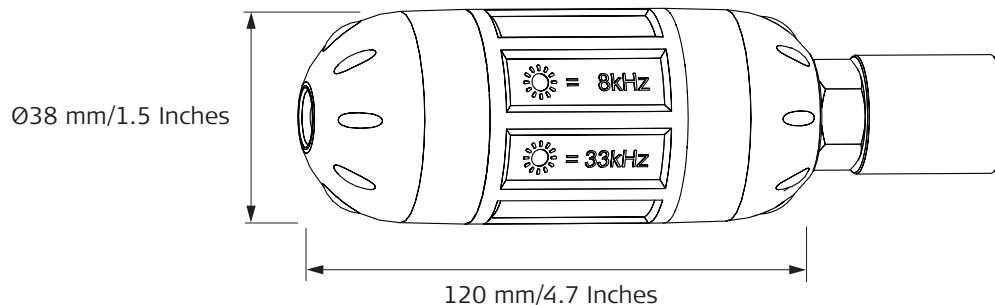
Instrument dimensions**Weight**

Instrument: 0.18 kg / 0.4 lbs
(including batteries)

Environmental specifications

Type		Description
Temperature	Operating	-20°C to +50°C -4°F to +122°F
	Storage	-40°C to +70°C -40°F to +158°F
Protection	against Water, Dust and Sand	Fully submersible
Humidity		95% RH non condensing The effects of condensation are to be effectively counteracted by periodically drying out the product.

Conformity to national regulations

- Hereby, Cable Detection Ltd, declares that the Sonde is in compliance with the essential requirements and other relevant provisions of Directive 1999/5/EC. The declaration of conformity may be consulted at <http://www.cabledetection.co.uk/ce>.
-  Class 1 equipment according European Directive 1999/5/EC (R&TTE) can be placed on the market and be put into service without restrictions in any EEA member state.
- The conformity for countries with other national regulations not covered by the FCC part 15 or European directive 1999/5/EC has to be approved prior to use and operation.

10.5

Property Connection Set Technical Data

Operating transmission frequencies

- 32.768 (33) kHz

Instrument dimensions

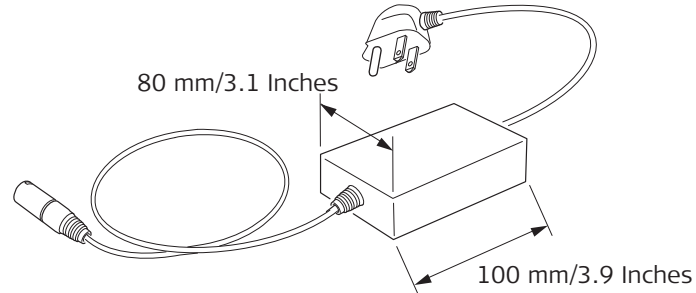

Weight

Instrument: 0.15 kg / 0.3 lbs

Environmental specifications

Type		Description
Temperature	Operating	-20°C to +50°C -4°F to +122°F
	Storage	-40°C to +70°C -40°F to +158°F
Protection	against Water, Dust and Sand	IP54 (IEC 60529) Dust-protected

Type	Description
Humidity	95% RH non condensing The effects of condensation are to be effectively counteracted by periodically drying out the product.

Conformity to national regulations

- Hereby, Cable Detection Ltd, declares that the Property Connection Set is in compliance with the essential requirements and other relevant provisions of Directive 1999/5/EC. The declaration of conformity may be consulted at <http://www.cabledetection.co.uk/ce>.



Class 1 equipment according European Directive 1999/5/EC (R&TTE) can be placed on the market and be put into service without restrictions in any EEA member state.

- The conformity for countries with other national regulations not covered by the FCC part 15 or European directive 1999/5/EC has to be approved prior to use and operation.

10.6

Signal Clamp Technical Data

Operating transmission frequencies

32.768 (33) kHz
when used with a signal transmitter set in 33 kHz mode.

Instrument dimensions

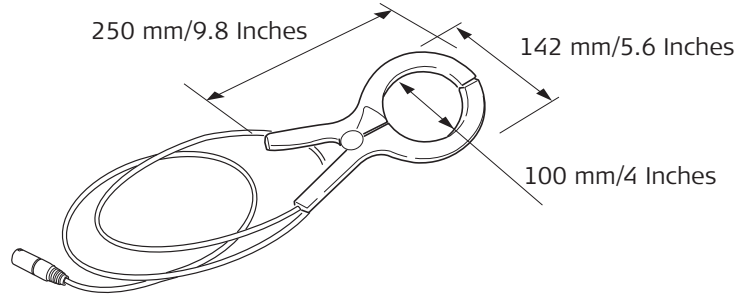

Weight

Instrument: 0.354 kg / 0.76 lbs

Environmental specifications

Type		Description
Temperature	Operating	-20°C to +50°C -4°F to +122°F
	Storage	-40°C to +70°C -40°F to +158°F
Protection	against Water, Dust and Sand	IP54 (IEC 60529) Dust-protected

Type	Description
Humidity	95% RH non condensing The effects of condensation are to be effectively counteracted by periodically drying out the product.

Conformity to national regulations

- Hereby, Cable Detection Ltd, declares that the Signal Clamp is in compliance with the essential requirements and other relevant provisions of Directive 1999/5/EC. The declaration of conformity may be consulted at <http://www.cabledetection.co.uk/ce>.
- 
- Class 1 equipment according European Directive 1999/5/EC (R&TTE) can be placed on the market and be put into service without restrictions in any EEA member state.
- The conformity for countries with other national regulations not covered by the FCC part 15 or European directive 1999/5/EC has to be approved prior to use and operation.

11**International Limited Warranty**

**International Limited
Warranty**

This product is subject to the terms and conditions set out in the International Limited Warranty which you can download from the Cable Detection home page at <http://www.cabledetection.co.uk/internationalwarranty> or collect from your Cable Detection distributor. The foregoing warranty is exclusive and is in lieu of all other warranties, terms or conditions, expressed or implied, either in fact or by operation of law, statutory or otherwise, including warranties, terms or conditions of merchantability, fitness for a particular purpose, satisfactory quality and noninfringement, all which are expressly disclaimed.

Appendix A

A.1

Functional Checks

Locator Functional Check

Checking the function

Before any tests can be carried out it is vital to check the status of the unit, its batteries and basic functionality.

The following list is used to achieve this.

1. Inspection

- **Casing** The casing should be free of significant damage.
- **Labels** Body labels must be legible and intact. Display label must be free of damage and tears.
- **Battery hatch** The hatch must lock into place.
- **Battery holder** All the battery contacts and springs on the holder must be free of corrosion and the holder in good condition.
- **Battery contacts** The battery contacts must be free of corrosion.

Once the general condition of the Locator is established the Audio Visual test can be performed.

2. Audio / Visual display test

Upon depressing the trigger the Locator should test the display and speakers by illuminating each segment in the bar display, the mode and function indicators and depth display, the battery indicator light will illuminate throughout the display test. All LCDs must be operative and an audible output must be heard.

3. Battery / Functional self check

If there is no response when the trigger is activated or the low battery illuminates (or flashes) after the Audio / Visual display test, the batteries will have to be replaced. Use alkaline batteries. Replace all of the batteries at the same time.

Checking the performance

The purpose of the following procedure is to verify the performance of the Locator. It is important that the test is conducted away from areas of electromagnetic interference or over buried services with a large signal radiating off them.

1. Switch the Locator on.
2. Whilst in Power mode hold down the i Button, until the settings are displayed.
3. Using the Function Button toggle through the settings until **EST** is displayed.
4. Press the i Button to activate the test.
5. Observe the displayed output:
 - PAS** means unit is within set tolerances.
 - ERR** means unit is outside set tolerances and may need servicing.



- Repeat the test in a different location if the units displays **ERR**.
- The Locator will automatically repeat the function test if it fails.
- Repeated failure will indicate a faulty unit, which must be returned for service.

Checking depth indication (i550, i650, i750, i550xf, i650xf, i750xf)

This test can be carried out provided the depth of a service on the test area is known.

1. Switch the Locator on and ensure that it is in 33 kHz mode.
2. Position the Locator directly over and at right angle to the service.
3. Press and release the i Button to activate the depth measurement.
4. Record the depth.
5. If the depth reading deviates from the normal value or an error code is displayed, the Locator should be returned for service.



If any of these tests give no response or a significantly different response from normal, the Locator should be returned for service.

Functional test check list

Functional Test Check List					
Unit: Locator...	Serial Number:			Comments:	
Test	Operative			Fail analysis	Notes
	Yes	No	N/A		
1. Casing				Return for repair/ Replace	Casing should be free of damage.
2. Labels				Return for repair/ Replace	Body labels must be legible and intact. Display label must be free of damage and tears.
3. Battery hatch				Return for repair/ Replace	Hatches must be free of corrosion.
4. Battery holder				Replace	Holder must be free of corrosion.
5. Battery contacts				Return for repair	Contacts must be free of corrosion.
6. Audio / Visual display test				Return for repair	LCD is illuminated and an audible output must be heard.

Functional Test Check List					
7. Batteries				Replace	Replace alkaline batteries if pack is exhausted (no response) or if the battery indicator light is illuminated or flashing after display test. Replace all batteries!
8. Power mode				Return for repair	Response width and peak value similar to test unit.
9. Radio mode				Return for repair	Response width and peak value similar to test unit.
10. 8 kHz				Return for repair	Response width and peak value similar to test unit.
11. 33 kHz				Return for repair	Response width and peak value similar to test unit.
12. Depth Mode (Depth Locator only) • 8 kHz, 33 kHz • 512 Hz, 640Hz (xf models)				Return for repair	Gives same result as test unit (10% accuracy).
Tested by:					Date:

Checking the function

The purpose of the following procedure is to verify the performance of the signal Transmitter.

Before any tests can be carried out it is vital to check the status of the unit, its batteries and basic functionality.

To carry out this test the following are required:

- The Transmitters cable Set.
- A fully charged battery pack.

1. Inspection

- **Casing** The casing should be free of significant damage.
- **Cable Set** The cable set should be free of damage to the cable's insulation and clip shrouds.
The terminals should be free of corrosion.
- **Labels** Body labels must be legible and intact. Display label must be free of damage and tears.
- **Battery hatch** The hatch must lock into place.
- **Battery holder** All the battery contacts and springs on the holder must be free of corrosion and the holder in good condition.
- **Battery contacts** The battery contacts must be free of corrosion.

Once the general condition of the Transmitter is established the Audio Visual test can be performed.

2. Audio / Visual display test

Turn on the Transmitter. All LED's will illuminate and the speaker will emit a tone. All LEDs must be operative and an audible output must be heard.

3. Battery check

The battery indicator flashes to indicate a poor battery condition. Replace all batteries with four new LR20 (D) type alkaline batteries, or remove and recharge the battery pack if rechargeable batteries are fitted.

Checking the performance

The purpose of the following procedure is to verify the performance of the Transmitter. It is important that the test is conducted away from areas of electromagnetic interference.

1. Plug the Transmitter's cable set into the connection socket.
2. Connect the black and red cable clips together, ensuring good metal to metal contact.
3. Hold down Frequency Control Button and switch the Transmitter on. Note, Hold the frequency control button down until the Extended Self Test has commenced.
4. Observe the displayed output:

Induction Mode Test	Mode Display:	Induction LED illuminated.
	Frequency Display:	Frequency LED illuminates showing the frequency on test.
Connection Mode Test	Mode Display:	Induction LED off.
	Mode Display:	Connection LED illuminated.
	Frequency Display:	Frequency LED's illuminates showing the frequency on test.
	Mode Display:	Connection LED off.

5. The transmitter will display the outcome.

Pass	Battery indicator:	LED Flash (if tested with poor batteries).
	Audible Output:	High - Low pulsed tone emitted three times.
Fail	Battery indicator:	LED Flash (if tested with poor batteries).
	Audible Output:	Low pitch tone emitted.
	Mode Display:	Induction or Connection LED illuminated to show failure mode.
	Frequency Display:	Frequency LED illuminated to show frequency failure.



- If the unit fails check the Transmitter's cable set is fully engaged and the clips are connected.
- Repeated failure will indicate a faulty unit, which must be returned for service.



If any of these tests give no response or a significantly different response from normal, the Transmitter should be returned for service.



Warning

The transmitter is capable of outputting potentially lethal voltages.

Precautions:

Care should be taken when handling exposed or non-insulated connections including; the connection cables sets, the Earth Pin and the connection to the service.

Notify others who may be working on or around the service.

Functional test check list

Functional Test Check List					
Unit: Transmitter...	Serial Number:			Comments:	
Test	Operative			Fail analysis	Notes
	Yes	No	N/A		
1. Casing				Return for repair/ Replace	Casing should be free of damage.
2. Labels				Return for repair/ Replace	Body labels must be legible and intact. Display label must be free of damage and tears.
3. Battery cover and accessory cover				Return for repair/ Replace	Hatches must lock into place.
4. Battery contacts				Return for repair	Contacts must be free of corrosion.
5. Audio / Visual display test				Return for repair	All LEDs must illuminate and an audible output must be heard.
6. Batteries				Replace	Replace alkaline batteries if exhausted (no response) or if the battery indicator light is illuminated or flashing after display test. Replace all batteries!

Functional Test Check List					
7. Induction mode				Return for repair/ Replace	Reduced or no output signal.
8. Connection mode; no change in audio indication				Return for repair/ Replace	Faulty cable.
9. Connection mode; no change in audio indication				Return for repair/ Replace	No output signal.
Tested by:					Date:

A.3

Conductive Rod Functional Check

Checking the function

The purpose of the following procedure is to verify the performance of the Conductive Rod.

To carry out this test the following are required:

- A Transmitter for generating the signal in the Sonde and Line mode tests
- The cable set for the Conductive Rod.

Plug the Transmitter's cable set into the connection socket. Connect the red cable to the positive (+) terminal on the conductive rod, connect the black cable to the negative (-) terminal.

Switch the Transmitter on and adjust the power output on the Transmitter to minimum, the audible output must be constant. Disconnect the black cable from the negative (-) terminal, the audible output must be pulsed.

If any of these tests give no response or a significantly different response from normal, the Conductive Rod should be returned for service.



Functional test check list

Functional Test Check List					
Unit: Conductive Rod...	Serial Number:			Comments:	
Test	Operative			Fail analysis	Notes
	Yes	No	N/A		
1. Sonde mode: Transmitter audio output does not go continuous				Repair or replace cable set	Faulty cable.
2. Sonde mode: Locator does not detect signal				Return for repair/ Replace	One or both internal wires are open or short circuit.
3. Line mode: Locator does not detect signal				Return for repair/ Replace	One or both internal wires are open or short circuit.
Tested by:					Date:

A.4

Sonde Functional Check

Checking the function

The purpose of the following procedure is to enable a user to verify the performance of the Sonde.

To carry out this test the following are required:

- A Locator to detect the signal.
- A work area free of services as illustrated.

1. Inspection

- **Casing** The casing should be free of significant damage, with the sealing ring and the screw thread intact

Once the general condition of the Sonde is established the self test can then be used to indicate the basic unit function and state of the batteries.

2. LED test

Turn on the sonde, the led display will illuminate.

3. Battery check

A dull LED, and lack of detection range will indicate poor battery condition. Use alkaline batteries.

1. Switch sonde on and activate 33kHz mode.
2. Set Locator to 33 kHz mode and aim at Sonde (see diagram).
3. At 2 m/6.56 ft the Locator must be at maximum.
4. Repeat this with Sonde and Locator in 8 kHz.

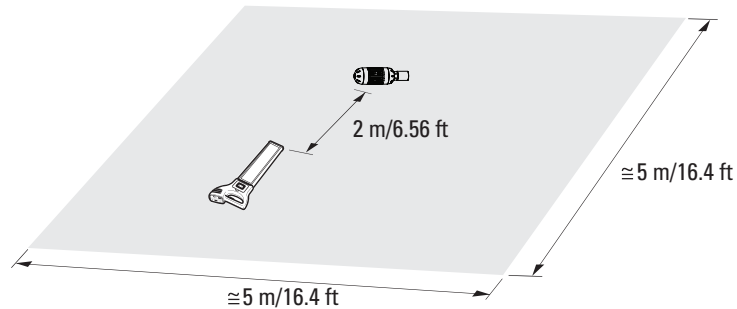

If any of these tests give no response or a significantly different response from normal, the Sonde should be returned for service.

Functional test check list

Functional Test Check List					
Unit: Sonde...		Serial Number:		Comments:	
Test	Operative			Fail analysis	Notes
	Yes	No	N/A		
1. Casing				Fail	Casing should be free of damage.
2. Screw thread and seal				Fail	Screw thread must be intact and seal in place.
3. Battery contacts				Fail	Contacts must be free of corrosion.
4. 33 kHz mode				Fail	LED must be illuminated brightly and pulse fast. Locator must provide maximum display at 2 metres.
5. 8 kHz mode				Fail	LED must be illuminated brightly and pulse slowly. Locator must provide maximum display at 2 metres.
Tested by:					Date:

Appendix B World Frequency Zones

North America

Canada	120 V / 60 Hz
United States	120 V / 60 Hz
Mexico	120 V / 50 Hz, 60 Hz

Central America

Bahamas	115 V / 60 Hz
Barbados	115 V / 50 Hz
Belize	110-220 V / 60 Hz
Bermuda	115 V / 60 Hz
Costa Rica	120 V / 60 Hz
Cuba	115-120 V / 60 Hz
Dominican Republic	110-220 V / 60 Hz
El Salvador	120-240 V / 60 Hz
Guatemala	115-230 V / 60 Hz
Haiti	110-220 V / 60 Hz
Honduras	110-220 V / 60 Hz
Jamaica	220 V / 50 Hz
Netherland Antilles	110-127 V / 50 Hz
Nicaragua	120 V / 60 Hz
Panama	120 V / 60 Hz
Puerto Rico	120 V / 60 Hz
Trinidad & Tobago	115-230 V / 60 Hz
Virgin Islands	120 V / 60 Hz

South America

Argentina	230 V / 50 Hz
Bolivia	110 V / 50 Hz
Brazil	110-127-220 V / 60 Hz
Chile	220 V / 50 Hz
Colombia	110-220 V / 60 Hz
Ecuador	110-220 V / 60 Hz
French Guiana	220 V / 50 Hz
Guyana	110-240 V / 60 Hz
Paraguay	220 V / 60 Hz
Peru	220 V / 60 Hz
Surinam	110-127 V / 60 Hz
Uruguay	220 V / 50 Hz
Venezuela	120-240 V / 60 Hz

Australia, Oceania

Australia	240 V / 50 Hz
Fiji Islands	240 V / 50 Hz
New Zealand	230 V / 50 Hz
Solomon Island	240 V / 50 Hz
Tonga	230 V / 50 Hz

Europe

Albania	230 V / 50 Hz	Slovenia	230 V / 50 Hz
Austria	230 V / 50 Hz	Spain	230 V / 50 Hz
Belgium	230 V / 50 Hz	Sweden	230 V / 50 Hz
Belarus	230 V / 50 Hz	Switzerland	230 V / 50 Hz
Bulgaria	230 V / 50 Hz	Ukraine	230 V / 50 Hz
Croatia	230 V / 50 Hz	United Kingdom	230 V / 50 Hz
Czech Republic	230 V / 50 Hz	Yugoslavia	230 V / 50 Hz
Denmark	230 V / 50 Hz		
Estonia	230 V / 50 Hz		
Finland	230 V / 50 Hz		
France	230 V / 50 Hz		
Germany	230 V / 50 Hz		
Greece	230 V / 50 Hz		
Hungary	230 V / 50 Hz		
Iceland	230 V / 50 Hz		
Ireland	230 V / 50 Hz		
Italy	230 V / 50 Hz		
Latvia	230 V / 50 Hz		
Lithuania	230 V / 50 Hz		
Luxemburg	230 V / 50 Hz		
Moldavia	230 V / 50 Hz		
Netherlands	230 V / 50 Hz		
Norway	230 V / 50 Hz		
Poland	230 V / 50 Hz		
Portugal	230 V / 50 Hz		
Romania	230 V / 50 Hz		
Russia	230 V / 50 Hz		
Slovakia	230 V / 50 Hz		

Africa

Algeria	127-220 V / 50 Hz	Niger	220 V / 50 Hz
Angola	220 V / 50 Hz	Nigeria	230 V / 50 Hz
Benin	220 V / 50 Hz	Rwanda	220 V / 50 Hz
Botswana	220 V / 50 Hz	Senegal	110 V / 50 Hz
Burkina Faso	220 V / 50 Hz	Sierra Leone	230 V / 50 Hz
Burundi	220 V / 50 Hz	Somalia	220 V / 50 Hz
Cameroon	127-220 V / 50 Hz	South Africa	220-240 V / 50 Hz
Central Africa Rep.	220 V / 50 Hz	Sudan	240 V / 50 Hz
Chad	220 V / 50 Hz	Swaziland	220 V / 50 Hz
Congo	220 V / 50 Hz	Tanzania	230 V / 50 Hz
Dahomey	220 V / 50 Hz	Togo	127-220 V / 50 Hz
Egypt	220 V / 50 Hz	Tunisia	127-220 V / 50 Hz
Ethiopia	220 V / 50 Hz	Uganda	240 V / 50 Hz
Gabon	220 V / 50 Hz	Zaire	220 V / 50 Hz
Gambia	230 V / 50 Hz	Zambia	220 V / 50 Hz
Ghana	240 V / 50 Hz	Zimbabwe	220 V / 50 Hz
Ivory Coast	220 V / 50 Hz		
Kenya	240 V / 50 Hz		
Lesotho	220-240 V / 50 Hz		
Liberia	120 V / 60 Hz		
Libya	115-220 V / 50 Hz		
Malawi	230 V / 50 Hz		
Mali	220 V / 50 Hz		
Mauritania	220 V / 50 Hz		
Mauritius	230 V / 50 Hz		
Morocco	127-220 V / 50 Hz		
Mozambique	220 V / 50 Hz		
Namibia	220 V / 50 Hz		

Asia			
Abu Dhabi	230 V / 50 Hz	Oman	240 V / 50 Hz
Afghanistan	220 V / 50 Hz	Pakistan	230 V / 50 Hz
Armenia	220 V / 50 Hz	Philippines	110-220 V / 60 Hz
Azerbaijan	220 V / 50 Hz	Qatar	240 V / 50 Hz
Bahrain	110-230 V / 50 Hz, 60 Hz	Saudi Arabia	127-220 V / 50 Hz
Bangladesh	230 V / 50 Hz	Singapore	230 V / 50 Hz
Brunei	240 V / 50 Hz	Sri Lanka	230 V / 50 Hz
Cambodia	220 V / 50 Hz	Syria	220 V / 50 Hz
China	220 V / 50 Hz	Taiwan	110-220 V / 60 Hz
Cyprus	240 V / 50 Hz	Tajikistan	220 V / 50 Hz
Georgia	220 V / 50 Hz	Thailand	220 V / 50 Hz
Hong Kong	220 V / 50 Hz	Turkey	220 V / 50 Hz
India	230-250 V / 50 Hz, 60 Hz	Turkmenistan	220 V / 50 Hz
Indonesia	127-220 V / 50 Hz	United Arab Emirates	220 V / 50 Hz
Iran	220 V / 50 Hz	Uzbekistan	220 V / 50 Hz
Iraq	220 V / 50 Hz	Vietnam	120-220 V / 50 Hz
Israel	230 V / 50 Hz	Yemen	220 V / 50 Hz
Japan	100-220 V / 50 Hz, 60 Hz		
Jordan	220 V / 50 Hz		
Kazakhstan	220 V / 50 Hz		
Kirgizstan	220 V / 50 Hz		
Korea (North)	220 V / 50 Hz		
Korea (South)	110-220 V / 60 Hz		
Kuwait	240 V / 50 Hz		
Laos	220 V / 50 Hz		
Lebanon	110-220 V / 50 Hz		
Malaysia	240 V / 50 Hz		
Myanmar	240 V / 50 Hz		

Index

C			
Conductive Rod			
Functional Check	107		
L			
Locator			
Functional Check	97		
O			
Operating depth range	80		
S			
Sonde			
Functional Check	109		
T			
Technical Data	80		
Temperature			
Conductive Rod			
Operating	89		
Storage	89		
Locator			
Operating	84		
Storage	84		
Property Connection Set			
Operating	92		
Storage	92		
Signal Clamp			
		Operating	94
		Storage	94
		Sonde	
		Operating	91
		Storage	91
		Transmitter	
		Operating	87
		Storage	87
		Transmitter	
		Functional Check	101
		Typical depth accuracy	80
		Typical detection range	
		Distance along conductor	80